

1966 FORD TRUCK



SHOP MANUAL



● INCLUDES ALL FOUR VOLUMES

Copyright © 2011, Forel Publishing Company, LLC, Woodbridge, Virginia

All Rights Reserved. No part of this book may be used or reproduced in any manner whatsoever without written permission of Forel Publishing Company, LLC. For information write to Forel Publishing Company, LLC, 3999 Peregrine Ridge Ct., Woodbridge, VA 22192

1966 Ford Truck Shop Manual

EAN: 978-1-60371-074-9

ISBN: 1-60371-074-4

Forel Publishing Company, LLC

3999 Peregrine Ridge Ct.

Woodbridge, VA 22192

Email address: sales@ForelPublishing.com

Website: <http://www.ForelPublishing.com>



This publication contains material that is reproduced and distributed under a license from Ford Motor Company. No further reproduction or distribution of the Ford Motor Company material is allowed without the express written permission of Ford Motor Company.

Note from the Publisher

This product was created from the original Ford Motor Company's publication. Every effort has been made to use the original scanned images, however, due to the condition of the material; some pages have been modified to remove imperfections.

Disclaimer

Although every effort was made to ensure the accuracy of this book, no representations or warranties of any kind are made concerning the accuracy, completeness or suitability of the information, either expressed or implied. As a result, the information contained within this book should be used as general information only. The author and Forel Publishing Company, LLC shall have neither liability nor responsibility to any person or entity with respect to any loss or damage caused, or alleged to be caused, directly or indirectly by the information contained in this book. Further, the publisher and author are not engaged in rendering legal or other professional services. If legal, mechanical, electrical, or other expert assistance is required, the services of a competent professional should be sought.

1966 FORD TRUCK

SHOP MANUAL VOLUME ONE



- VEHICLE IDENTIFICATION
- BRAKES
- SUSPENSION, STEERING, WHEELS AND TIRES
- REAR AXLE
- DRIVE SHAFT AND CLUTCH
- MANUAL SHIFT TRANSMISSION
- AUTOMATIC TRANSMISSION

1966 FORD TRUCK

SHOP MANUAL

VOLUME ONE



SERVICE PUBLICATIONS

FIRST PRINTING—APRIL, 1966
©1966 FORD MOTOR COMPANY, DEARBORN, MICHIGAN

GROUP INDEX

VEHICLE IDENTIFICATION	1
BRAKES	2
SUSPENSION, STEERING, WHEELS AND TIRES	3
REAR AXLE	4
DRIVE SHAFT AND CLUTCH	5
MANUAL SHIFT TRANSMISSION	6
AUTOMATIC TRANSMISSION	7
ENGINE	8
IGNITION SYSTEM	9
FUEL SYSTEM	10
COOLING SYSTEM	11
EXHAUST SYSTEM	12
CHARGING SYSTEM	13
STARTING SYSTEM	14
LIGHTING SYSTEM, HORNS AND INSTRUMENTS	15
VENTILATING, HEATING AND ACCESSORIES	16
BODY, DOORS AND WINDOWS	17
TRIM AND SEATS	18
MAINTENANCE SCHEDULE	19
MAINTENANCE OPERATIONS	20
LUBRICATION CHARTS AND SPECIFICATIONS	21

SPECIFICATIONS AND SPECIAL SERVICE TOOLS
AT END OF EACH GROUP

FOREWORD

The four volumes of this shop manual provide the Service Technician with complete information for the proper servicing of all 1966 Ford Trucks except Econoline and Ranchero.

The information is grouped according to the type of work being performed, such as diagnosis and testing, frequently performed adjustments and repairs, in-vehicle adjustments, overhaul, etc. Specifications, maintenance information and recommended special tools are included.

Refer to the opposite page for important vehicle identification data.

The descriptions and specifications in this manual were in effect at the time this manual was approved for printing. The Ford Motor Company reserves the right to discontinue models at any time, or change specifications or design, without notice and without incurring obligation.



SERVICE PUBLICATIONS

Vehicle Identification

GROUP

1

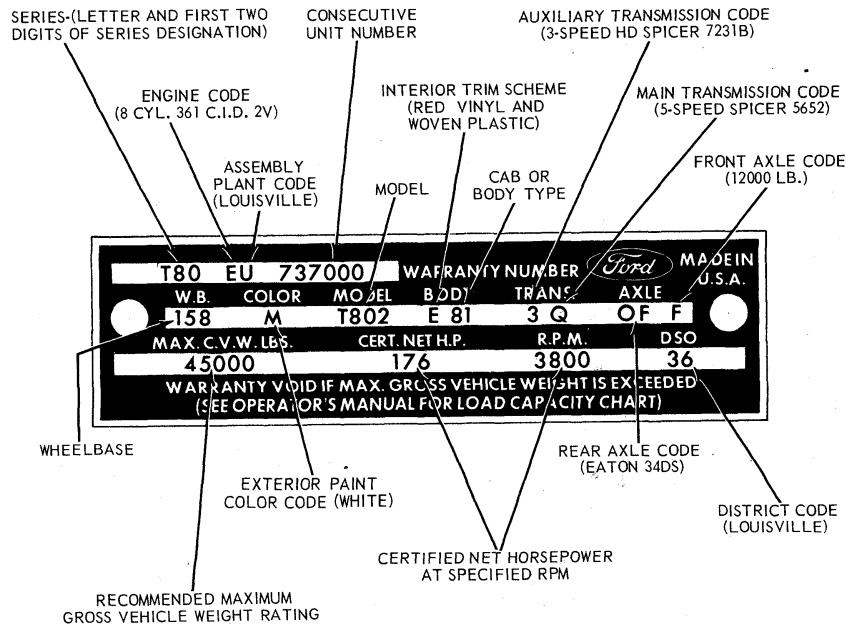

P 1116-D

Fig. 1—Typical Truck Rating Plate

RATING PLATE

Figure 1 illustrates a typical truck Rating Plate. The Rating Plate is riveted to the rear (lock) face of the left front door on Conventional Cabs, 89 inch BBC (bumper-to-back of cab) and Tilt Cab trucks. On cowl and windshield units, the Rating Plate is mounted on the glove compartment inner panel inside the glove compartment door.

The Official Serial Number, for title and registration purposes, is stamped on the following locations: P-Series—right frame side rail approximately 4 inches to rear of the front crossmember; N, NT, F, T and B-Series—right frame side rail approximately 24 inches forward of the No. 2 crossmember; C-Series—10 inches forward of the rear cab support on the upper flange of the right frame side rail.

Do not use the Warranty Number which appears on the Rating Plate for title or registration purposes.

VEHICLE WARRANTY NUMBER

The Warranty Number is the first line of numbers and letters appearing on the Rating Plate (Fig. 1). The first letter and two numbers indicate the truck model and series (the letter prefix identifies the type of body or cab and the numbers are the first two numbers of a truck series). The letter following the truck series code designates the engine identification code. The letter following the engine identification code indicates the assembly plant at which the vehicle was built. The remaining numbers indicate the consecutive unit number. The charts that follow list the various vehicle warranty number codes.

VEHICLE DATA

The Vehicle Data appears on the Rating Plate on the two lines following the Warranty Number. The first three digits under W.B. designate the wheelbase in inches. The one or two letters under COLOR identify the exterior paint color (two letters designate a two-tone). The letter and three digits

under MODEL designate the truck model within a series. The letter and numerals under BODY designate the interior trim and body type (the letter identifies the interior trim scheme and the numerals identify the body or cab type). The transmission installed in the vehicle is identified under TRANS by either a numeric or alphabetical code (if two symbols appear, the first identifies the auxiliary transmission, if so equipped, and the second symbol identifies the main transmission). A letter and a number or two numbers under AXLE identify the rear axle ratio (when required, a letter is also stamped behind the rear axle code to identify the front axle capacity). The maximum gross vehicle weight in pounds is stamped under MAX. G.V.W. Following MAX. G.V.W., the horsepower rating of the engine with which the vehicle is equipped, is stamped under CERT. NET H.P. and the rpm required to develop the given horsepower is stamped under R.P.M. A two-digit number is stamped under D.S.O. to identify the district which ordered the vehicle. If the vehicle is built to special order (Domestic Special Order, Foreign Special Order, Limited Production Option, or other special order), the complete order number will also appear under D.S.O. The charts that follow list the various vehicle data codes.

W. B. (Wheelbase)

The wheelbase in inches is entered in this space.

MAX. G.V.W. Lbs.

The maximum gross vehicle weight in pounds is recorded in this space.

CERT. Net H.P. R.P.M.

The certified net horsepower at specified rpm is marked at this location.

D.S.O.

If vehicle is built on a D.S.O., F.S.O., L.P.O. (special orders) the complete order number will be reflected under the DSO space including the District Code Number.

PREFIX	TYPE
A	Fwd. Axle Tilt Cab Tandem Rear Axle—Diesel
B	School Bus Chassis—Gas
C	Tilt Cab 2 Axle—Gas
D	Tilt Cab 2 Axle—Diesel
F	Conventional 2 Axle—Gas
H	Forward Axle Tilt Cab 2 Axle—Gas
J	Fwd. Axle Tilt Cab Tandem Rear Axle—Gas
K	Conventional 2 Axle—Diesel
L	Tilt Cab Tandem Rear Axle—Gas
N	.89" BBC Conventional 2 Axle—Gas
P	Parcel Delivery
U	Conventional Tandem Rear Axle—Diesel
R	.89" BBC Conventional 2 Axle—Diesel
S	.89" BBC Conventional Tandem Rear Axle—Gas
T	Conventional Tandem Rear Axle—Gas
W	.89" Conventional Tandem Rear Axle—Diesel
Y	Fwd. Axle Tilt Cab 2 Axle—Diesel

Fig. 2—Model Code Prefix

P1124-A

CODE LETTER	ASSEMBLY PLANT	CODE LETTER	ASSEMBLY PLANT
C	Ontario	N	Norfolk
D	Dallas	P	Twin Cities
E	Mahwah	R	San Jose
H	Lorain	S	Pilot Plant
K	Kansas City	U	Louisville
L	Michigan Truck		

Fig. 3—Assembly Plant Codes

P1126-A

Basically, the system assigns the monthly assignment of serial numbers into blocks as follow, beginning with August, 1965.

	Louisville Heavy Truck	Louisville Medium Truck	Plants Except Louisville
			732,000 thru 745,999
Sept.	751,000 thru 759,999	746,000 thru 750,999	746,000 thru 759,999
Oct.	765,000 thru 773,999	760,000 thru 764,999	760,000 thru 773,999
Nov.	779,000 thru 787,999	774,000 thru 778,999	774,000 thru 787,999
Dec.	793,000 thru 801,999	788,000 thru 792,999	788,000 thru 801,999
Jan.	807,000 thru 815,999	802,000 thru 806,999	802,000 thru 815,999
Feb.	821,000 thru 829,999	816,000 thru 820,999	816,000 thru 829,999
March	835,000 thru 843,999	830,000 thru 834,999	830,000 thru 843,999
April	849,000 thru 857,999	844,000 thru 848,999	844,000 thru 857,999
May	863,000 thru 871,999	858,000 thru 862,999	858,000 thru 871,999
June	877,000 thru 885,999	872,000 thru 876,999	872,000 thru 885,999
July	891,000 thru 899,999	886,000 thru 890,999	886,000 thru 899,999
August	905,000 thru 913,999	900,000 thru 904,999	900,000 thru 913,999

Fig. 4—Consecutive Unit Number

P1127-A

CODE	ENGINE
A	6 Cyl. 240 CID (1V) ①
B	6 Cyl. 300 CID (1V) ①
C	8 Cyl. 330 CID (2V-MD) ①
D	8 Cyl. 330 CID (2V-HD) ①
E	8 Cyl. 361 CID (2V) ①
F	8 Cyl. 391 CID (4V) ①
G	8 Cyl. 401 CID (2V) ①
H	8 Cyl. 401 CID (4V) ①
J	8 Cyl. 477 CID (2V) ①
K	8 Cyl. 477 CID (4V) ①
L	8 Cyl. 534 CID (4V) ①
V	6 Cyl. 330 CID Diesel Ford (DGHM) ②
Y	8 Cyl. 352 CID (2V) ①
B	6 Cyl. 588 CID Cummins (V6E-195) ②
C	6 Cyl. 743 CID Cummins (NHE-180) ②
D	6 Cyl. 743 CID Cummins (NHE-195) ②
E	6 Cyl. 743 CID Cummins (NH-220) ②
F	8 Cyl. 785 CID Cummins (V8E-235) ②
G	8 Cyl. 784 CID Cummins (V8-265) ②
H	6 Cyl. 855 CID Cummins (NHE-225) ②
J	6 Cyl. 855 CID Cummins (NH-250) ②
K	1673 Caterpillar ②
L	1673 Caterpillar ②
M	855 Cummins - NTC-260 ②
N	855 Cummins - NTC-280 ②
P	855 Cummins - NTC-300 ②
Q	855 Cummins - NTC-320 ②
R	855 Cummins - NTC-335 ②
S	Detroit 6-71N ②
T	Detroit 8V-71N ②
U	4 Cyl. 220 CID Diesel Ford (DGHM) ②
X	464 Cummins (CF-160) ②
Y	464 Cummins (C-180) ②
Z	464 Cummins (C-160) ②
8	Detroit 6V-53N ②
1	6 Cyl. 240 CID (1V) ① ③
2	6 Cyl. 300 CID (1V) ① ③
3	8 Cyl. 330 CID (2V-MD) ① ③
4	8 Cyl. 330 CID (2V-HD) ① ③
5	8 Cyl. 361 CID (2V) ① ③
8	8 Cyl. 352 CID (2V) ① ③

① Gas ② Diesel ③ Low Compression

Fig. 5—Engine Codes

P1125-A

CODE	M-30J/M-32J ① SPEC. NUMBER	COLOR
A	1724-A	Black
B	556-A	Turquoise
F	1226-A	Light Blue
C	1525-A	White
G	1526-A	Chrome Yellow
H	1912-A	Light Beige
J	1515-A	Red
L	1237-A	Dark Green
M	1619-A	White
W	1742-A	Med. Blue
Y	1269-A	Med. Blue Met.
3	1623-A	Light Blue
8	1955-A	Yellow

① M-32J Acrylic Enamel Alternate with M-30J Alkyd.

Fig. 6—Exterior Paint Color Codes

P1128-A

VEHICLE IDENTIFICATION

Series	Model Code	Rating G V W (lbs)	Nominal (ton)	Series	Model Code	Rating G V W (lbs)	Nominal (ton)	Series	Model Code	Rating G V W (lbs)	Nominal (ton)
B-500	B-500	15,000	1½	C-800	C-800	27,000	3½	F-800	F-805	23,000	2½
	B-501	10,000	1		C-801	20,000	2		F-806	25,500	3
	B-502	16,000	1½		C-802	27,500	3½		F-807	27,500	3½
	B-503	17,000	2		C-803	27,500	3½		F-808	27,500	3½
	B-504	18,000	2		C-804	27,500	3½		F-809	25,500	3
	B-505	20,000	2		C-805	27,500	3½				
B-600	B-600	17,000	2	CT-750	L-750	39,000	3½	N-500	N-500	15,000	1½
	B-601	15,000	1½		L-751	27,000	2½		N-501	10,000	1
	B-602	20,000	2		L-752	41,000	4		N-502	16,000	1½
	B-610	21,000	2½	CT-800	L-800	43,000	4		N-503	17,000	2
	B-611	22,000	2½		L-801	27,000	2½		N-504	18,000	2
	B-612	23,000	2½		L-802	39,000	3½	N-505	20,000	2	
B-700	B-700	20,500	2½	F-500	F-500	15,000	1½	N-600	N-600	17,000	2
	B-701	17,000	2		F-501	10,000	1		N-601	15,000	1½
	B-702	21,000	2½		F-502	16,000	1½		N-602	20,000	2
	B-703	22,500	2½		F-503	17,000	2		N-610	21,000	2½
	B-704	23,000	2½	F-504	18,000	2	N-611		22,000	2½	
	B-705	24,000	2½	F-505	20,000	2	N-612	23,000	2½		
	B-706	25,500	3	F-600	F-600	17,000	2	N-613	23,000	2½	
	B-707	23,000	2½		F-601	15,000	1½	N-614	23,000	2½	
	B-708	23,000	2½		F-602	20,000	2	N-615	24,000	2½	
B-750	B-750	22,500	2½		F-610	21,000	2½	N-700	N-700	22,000	2½
	B-751	17,000	2		F-611	22,000	2½		N-701	17,000	2
	B-752	23,000	2½		F-612	23,000	2½		N-702	23,000	2½
	B-753	24,000	2½	F-613	23,000	2½	N-703		24,000	2½	
	B-754	25,500	3	F-614	23,000	2½	N-704		25,500	3	
	B-755	23,000	2½	F-700	F-700	22,000	2½		N-705	23,000	2½
B-756	23,000	2½	F-701		17,000	2	N-706		23,000	2½	
C-550	C-550	15,000	1½		F-702	23,000	2½		N-707	25,500	3
	C-551	10,000	1		F-703	24,000	2½	N-708	25,500	3	
	C-552	17,000	2		F-704	25,500	3	N-750	N-750	22,500	2½
	C-553	19,000	2		F-705	23,000	2½		N-751	17,000	2
	C-554	20,000	2		F-706	23,000	2½		N-752	23,000	2½
C-600	C-600	20,000	2	F-707	25,500	3	N-753		24,000	2½	
	C-601	15,000	1½	F-750	F-750	22,500	2½		N-754	25,500	3
	C-610	21,000	2½		F-751	17,000	2		N-755	23,000	2½
	C-611	22,000	2½		F-752	23,000	2½		N-756	25,500	3
	C-612	22,000	2½		F-753	24,000	2½		N-757	23,000	2½
	C-613	22,000	2½		F-754	25,500	3	N-758	25,500	3	
	C-614	22,000	2½		F-755	23,000	2½	T-700	T-700	28,000	3
C-700	C-700	24,000	2½		F-756	25,500	3		T-701	22,000	2
	C-701	17,000	2	F-757	23,000	2½	T-702		29,000	3	
	C-702	25,500	3	F-758	27,500	3½	T-703		36,000	3½	
	C-703	25,500	3	F-759	28,000	3½	T-704	37,000	3½		
C-750	C-750	24,000	2½	F-800	F-800	23,000	2½	T-750	T-750	37,000	3½
	C-751	17,000	2		F-801	17,000	2		T-751	27,000	2½
	C-752	25,500	3		F-802	24,000	2½		T-752	39,000	3½
	C-753	25,500	3		F-803	25,500	3		T-753	41,000	4
	C-754	25,500	3	F-804	27,500	3½	T-800	T-800	43,000	4	
C-755	27,500	3½				T-801		27,000	2½		
						T-802		45,000	4		
						T-803		49,000	5		
							T-804	43,000	4		

Fig. 7—Series, Model Codes, and Gross Vehicle Weight (G.V.W.) -500 - 800 Series

VEHICLE IDENTIFICATION

Series	Model Code	Rating G V W (lbs)	Nominal (ton)	Series	Model Code	Rating G V W (lbs)	Nominal (ton)	Series	Model Code	Rating G V W (lbs)	Nominal (ton)		
F-850	F-850	25,000	3	HT-950	J-950	41,000	4	T-850	T-856	49,000	5		
	F-851	20,000	2		J-951	32,000	3		T-858	45,000	4		
	F-852	25,000	3		J-952	45,000	4		T-859	51,000	6		
	F-853	27,000	3½		H-1000	J-953	49,000	5	T-950	T-950	47,000	5	
	F-854	27,000	3½			H-000	30,000	4		T-951	30,000	3½	
	F-855	27,000	3½			H-001	24,000	2½		T-952	49,000	5	
	F-856	25,500	3			H-002	32,000	4½		T-953	53,000	6	
	F-857	27,500	3½			H-003	34,000	5		T-954	55,000	7	
	F-858	25,500	3		*H-1000-D	Y-000	32,000	4½		T-955	59,000	8	
	F-950	F-950	28,000			3½	Y-001	26,000		3	T-956	65,000	9
F-951		24,000	2½	Y-002		34,000	5	T-957		75,000	10		
F-952		30,000	4	*N-1000-D		R-000	32,000	4½		T-958	78,000	10	
F-953		30,000	4		R-001	26,000	3	N-950		N-950	28,000	3½	
F-954		32,000	4½		R-002	34,000	5		N-951	24,000	2½		
F-955		32,000	4½		R-003	36,000	5		N-952	30,000	4		
F-956		34,000	5	R-004	27,500	3½	N-953		30,000	4			
F-957		29,000	3½	NT-850	S-850	39,000	3½		N-954	32,000	4½		
F-958		31,000	4		S-851	27,000	2½		N-955	32,000	4½		
F-959		33,000	4½		S-852	41,000	4		N-956	34,000	5		
CT-800	L-800	43,000	4		S-853	43,000	4		N-957	29,000	3½		
	L-801	27,000	2½		S-854	43,000	4		N-958	31,000	4		
	L-802	39,000	3½		S-855	45,000	4		N-959	33,000	4½		
	L-803	45,000	4		S-856	49,000	5	NT-950	S-950	47,000	5		
	L-804	49,000	5		S-857	43,000	4		S-951	30,000	3½		
CT-850	L-850	39,000	3½		NT-850-D	W-850	43,000		4	S-952	49,000	5	
	L-851	27,000	2½			W-851	27,000	2½	S-953	53,000	6		
	L-852	41,000	4	W-852		39,000	3½	*NT-950-D	W-950	47,000	5		
	L-853	43,000	4	W-853		41,000	4		W-951	30,000	3½		
	L-854	45,000	4	W-854		45,000	4		W-952	49,000	5		
L-855	49,000	5	W-855	49,000	5	*T-950-D	U-950	47,000	5				
CT-950	L-950	47,000	5	*T-850-D	U-850		39,000	3½	U-951	30,000	3½		
	L-951	30,000	3½		U-851		27,000	2½	U-952	49,000	5		
	L-952	49,000	5		U-852		41,000	4	U-953	53,000	6		
	L-953	53,000	6		U-853		43,000	4	U-954	56,000	7		
	N-850	N-850	25,000		3	U-854	45,000	4	*HT-950-D	A-950	41,000	4	
N-851		20,000	2	U-855	49,000	5	A-951	32,000		3			
N-852		25,000	3	U-856	51,000	6	A-952	45,000		4			
N-853		27,000	3½	*F-950-D	K-950	28,000	3½	A-953		49,000	5		
N-854		27,000	3½		K-951	24,000	2½	C-6000	D-600	20,000	2		
N-855		27,000	3½		K-952	30,000	4		D-601	15,000	1½		
N-856		25,500	3		K-953	30,000	4		D-610	21,000	2½		
N-857		27,500	3½		K-954	32,000	4½		D-611	22,000	2½		
N-858		25,500	3		K-955	32,000	4½		D-612	23,000	2½		
*F-1000-D		K-000	32,000		4½	K-956	34,000	5	D-613	23,000	2½		
	K-001	26,000	3		K-957	29,000	3½	D-614	23,000	2½			
	K-002	34,000	5		K-958	31,000	4	C-7000	D-700	24,000	2½		
	K-003	36,000	5		K-959	33,000	4½		D-701	17,000	2		
	N-1000	C-950	C-950	30,000	4	K-960	25,500		3	D-702	25,500	3	
C-951			24,000	2½	K-961	27,500	3½		D-703	25,500	3		
C-952			30,000	4	C-1000	C-000	32,000		4½	D-704	25,500	3	
C-953			32,000	4½		C-001	26,000	3	F-8000	K-800	24,000	2½	
C-954			32,000	4½		C-002	34,000	5		K-801	20,000	2	
C-955			34,000	5		C-003	36,000	5		K-802	25,500	3	
C-956			34,000	5		T-850	T-850	39,000		3½	K-803	27,500	3½
C-957			31,000	4			T-851	27,000		2½	K-804	27,500	3½
C-958			33,000	4½			T-852	41,000		4	K-805	27,500	3½
F-1000			F-000	32,000			4½	T-853	43,000	4	K-806	24,000	3½
	F-001	26,000	3	T-854			43,000	4	T-8000	U-800	39,000	3½	
	F-002	34,000	5	T-855		45,000	4	U-801		27,000	2½		
	F-003	36,000	5	C-850	C-850	27,000	3½	U-802		41,000	4		
	C-850	C-851	20,000		2	C-851	20,000	2		U-803	43,000	4	
C-852		27,000	3½		C-852	27,000	3½	U-804		45,000	4		
C-853		27,000	3½		C-853	27,000	3½	U-805	49,000	5			
C-854		27,000	3½		C-854	27,000	3½	CT-8000	Q-800	43,000	4		
C-855		27,500	3½		C-855	27,500	3½		Q-801	27,000	2½		
C-856		27,500	3½		C-856	27,500	3½		Q-802	39,000	3½		
CT-800		L-800	43,000		4	CT-850	L-850		39,000	3½	Q-803	45,000	4
		L-801	27,000		2½		C-851		20,000	2	Q-804	49,000	5
		L-802	39,000		3½		C-852	27,000	3½	F-8000	K-800	24,000	2½
		L-803	45,000	4	C-853		27,000	3½	K-801		20,000	2	
	L-804	49,000	5	C-854	27,000		3½	K-802	25,500		3		
CT-850	L-850	39,000	3½	C-855	27,500	3½	K-803	27,500	3½				
	L-851	27,000	2½	C-856	27,500	3½	K-804	27,500	3½				
	L-852	41,000	4	F-1000	F-000	32,000	4½	K-805	27,500		3½		
	L-853	43,000	4		F-001	26,000	3	K-806	24,000		3½		
	L-854	45,000	4		F-002	34,000	5	T-8000	U-800		39,000	3½	
L-855	49,000	5	F-003		36,000	5	U-801		27,000		2½		
CT-950	L-950	47,000	5		C-1000	C-000	32,000		4½		U-802	41,000	4
	L-951	30,000	3½			C-001	26,000		3	U-803	43,000	4	
	L-952	49,000	5			C-002	34,000		5	U-804	45,000	4	
	L-953	53,000	6			C-003	36,000	5	U-805	49,000	5		
	N-850	N-850	25,000			3	T-850	T-850	39,000	3½	CT-8000	Q-800	43,000
N-851		20,000	2			T-851		27,000	2½	Q-801		27,000	2½
N-852		25,000	3	T-852		41,000		4	Q-802	39,000		3½	
N-853		27,000	3½	T-853		43,000		4	Q-803	45,000		4	
N-854		27,000	3½	T-854		43,000		4	Q-804	49,000		5	
N-855		27,000	3½	T-855		45,000	4						
N-856		25,500	3										
N-857		27,500	3½										
N-858		25,500	3										

Fig. 8—Series, Model Codes, and Gross Vehicle Weights (G.V.W.)—850 - 1000 Series

P1132-A

Series	Model Code	Rating G V W (lbs)	Nominal (ton)	Series	Model Code	Rating G V W (lbs)	Nominal (ton)	Series	Model Code	Rating G V W (lbs)	Nominal (ton)	
F-100	F-100	5,000	½	F-250 (4x4)	F-260	6,800	¾	P-500	P-500	15,000	1½	
	F-101	4,200	½		F-261	4,900	½		P-501	10,000	1	
	F-102	5,000	½		F-262	7,700	¾	P-600	P-600	17,000	2	
F-100 (4x4)	F-110	5,600	½	F-350	F-350	10,000	1		P-601	15,000	1½	
	F-111	4,900	½		F-351	8,000	¾	P-3500	G-350	8,000	¾	
	F-112	5,600	½	P-100	P-100	4,300	½		G-351	5,900	½	
P-100	P-100	4,300	½		P-350	P-350	8,000	¾	P-4000	G-400	10,000	1
	P-101	5,000	½	P-351		5,900	½	G-401		7,700	¾	
F-250	F-250	7,500	¾	P-400	P-400	10,000	1	G-402		8,000	¾	
	F-251	4,800	½		P-401	P-401	7,700	¾	P-5000	G-500	15,000	1½
	F-252	7,500	¾			P-402	8,000	¾		G-501	10,000	1

Fig. 9—Series, Model Codes and Gross Vehicle Weights (G.V.W.)—100-350 and P Series

P1129-A

Series	Model Code	Rating G V W (lbs)	Nominal (ton)	Series	Model Code	Rating G V W (lbs)	Nominal (ton)	Series	Model Code	Rating G V W (lbs)	Nominal (ton)
C-6000	D-600	20,000	2	C-7000	D-702	25,500	2½	N-6000	R-614	23,000	2½
	D-601	15,000	1½		D-703	25,500	3		R-615	24,000	2½
	D-610	21,000	2½		D-704	25,500	3	N-7000	R-700	22,000	2½
	D-611	22,000	2½	N-6000	R-600	20,000	2		R-701	17,000	2
	D-612	23,000	2½		R-601	15,000	1½		R-702	23,000	2½
	D-613	23,000	2½		R-610	21,000	2½		R-703	24,000	2½
	D-614	23,000	2½		R-611	22,000	2½		R-704	25,500	3
C-7000	D-700	24,000	2½		R-612	23,000	2½	R-705	23,000	2½	
	D-701	17,000	2	R-613	23,000	2½	R-706	23,000	2½		

Fig. 10—Series, Model Codes and Gross Vehicle Weights (G.V.W.). Dagenham Diesel Powered Units

P1131-A

CODE	TRIM SCHEME
1.....	Grey Vinyl
2.....	Blue Vinyl
3.....	Green Vinyl
4.....	Biege Vinyl
5.....	Red Vinyl
6.....	Black Vinyl
A.....	Grey Woven Plastic and Vinyl
B.....	Blue Woven Plastic and Blue Vinyl w/Foam Cushion
C.....	Green Woven Plastic and Green Vinyl w/Foam Cushion
D.....	Beige Woven Plastic and Beige Vinyl w/Foam Cushion
E.....	Red Woven Plastic and Red Vinyl w/Foam Cushion
J.....	Gray Vinyl w/Foam Cushion
K.....	Blue Woven Plastic and Blue Vinyl w/Foam Cushion
L.....	Green Woven Plastic and Green Vinyl w/Foam Cushion
M.....	Beige Woven Plastic and Beige Vinyl w/Foam Cushion
N.....	Red Woven Plastic and Red Vinyl w/Foam Cushion
O.....	Black Vinyl w/Foam Cushion

Fig. 11—Interior Trim Codes

P1133-A

CODE	BODY TYPE
81.....	Conventional Cab
84.....	Cowl and Chassis
85.....	Cowl and Windshield
91.....	Tilt Cab

Fig. 12—Body Codes

P1136-A

CODE ①	TYPE	RATIO
1	3 Speed Spicer.....	5831-C 1.27/ .85
2	3 Speed Spicer.....	5831-D 2.0 / .85
3	3 Speed H. D. Spicer.....	7231-B 1.24/ .86
4	3 Speed H. D. Spicer.....	7231-D 2.14/ .86
5	4 Speed Spicer.....	8341-C 2.40/1.29/.84
6	3 Speed Spicer.....	8031-C 2.59/ .79
7	3 Speed Spicer.....	8031-P 1.19/ .84
8	4 Speed Spicer.....	7041 2.31/1.21/.83

NOTE: When required, the auxiliary transmission code will be stamped directly in front of the transmission code.

① If the "New Process" transmission is installed, the auxiliary transmission code will bear the suffix "N".

Fig. 13—Auxiliary Transmission Codes

P1134-A

CODE	DESCRIPTION
A.....	4-Speed New Process
B.....	3-Speed O/Drive
C.....	3-Speed Ford L. D.
D.....	3-Speed Warner M. D.
E.....	3-Speed Warner H. D.
F.....	4-Speed Syn. Warner
G.....	Automatic (C-4)
H.....	5-Speed Clark 305-V Dir.
I.....	5-Speed Clark 307-V Dir.
J.....	5-Speed Clark 264-VO O/Drive
K.....	5-Speed Clark 251-VO O/Drive
L.....	5-Speed Clark 2653-V1 Dir.
M.....	5-Speed Clark 250-V Dir.
N.....	5-Speed Clark 2622-V1 Dir.
Q.....	5-Speed Spicer 5652 Dir.
S.....	5-Speed Spicer 5756-B Dir.

Fig. 14—Transmission Codes -100-750 Series

P1135-A

VEHICLE IDENTIFICATION

CODE	DESCRIPTION
A	4-Speed New Process 435
A	5-Speed Spicer 8052 Direct (Iron)
B	10-Speed Fuller R-96 Direct (Iron)
C	10-Speed Fuller RA-96 Direct (Alum.)
D	10-Speed Fuller RA-960 O/Drive (Alum.)
E	10-Speed Fuller R-960 O/Drive (Iron)
F	5-Speed Fuller 5H74 Direct
G	5-Speed Fuller 5H75 Direct
H	5-Speed Clark 305-V Direct
I	5-Speed Clark 307-V Direct
J	5-Speed Clark 264-VO O/Drive
J	5-Speed Spicer 8051-C O/Drive (Iron)
K	5-Speed Clark 251-VO O/Drive
K	5-Speed Spicer 6453-A O/Drive (Iron)
L	5-Speed Clark 2653 V1 Direct
L	5-Speed Spicer 6352-B Direct (Iron)
M	5-Speed Clark 250-V Direct
M	5-Speed Spicer 6452-A Direct (Iron)
N	5-Speed Clark 2622 V1 Direct
N	5-Speed Spicer 6352 Direct (Iron)
O	5-Speed Spicer 8055-C O/Drive (Alum.)
P	5-Speed Spicer 8054 Direct (Alum.)
Q	5-Speed Spicer 5652 Direct
R	12-Speed Spicer 8125 O/Drive (Alum.)
S	5-Speed Spicer 5756-B Direct
T	8-Speed Fuller R-46 Direct
U	5-Speed Spicer 6852-G Direct (Iron)
V	10-Speed Fuller RT-910 Direct
V	5-Speed T-905 Direct
W	10-Speed Fuller RTO-910 O/Drive
W	5-Speed Fuller 5HA-74 Direct (Alum.)
X	6-Speed Transmatic MT-30
X	5-Speed Fuller 5HA-75 Direct (Alum.)
Y	6-Speed Transmatic MT-40
1	6-Speed Transmatic MT-42
2	5-Speed Spicer 6354 Direct (Alum.)
3	5-Speed Spicer 6455-A O/Drive (Alum.)
4	5-Speed Spicer 6854-G Direct (Alum.)
5	5-Speed Spicer 6454-A Direct (Alum.)
6	5-Speed Spicer 6354-B Direct (Alum.)

Fig. 15—Transmission Codes -500 -1000 Series P1137-A

CODE	CAPACITY
A	5.5M ①
B	5.5M ①
C	6M ①
D	7M ①
E	9M ①
F	11M ①
G	12M ①
H	15M ①
I	18M ①
L	6M ① ②
M	6M ① ② or 7M ① ②
N	9M ① ②

① Pounds Capacity in Thousands.
② Heavy Duty Front Brakes.

Fig. 16—Front Axle Codes

P1141-A

CODE	DISTRICT	CODE	DISTRICT
11	Boston	45	Davenport
12	Buffalo	51	Denver
13	New York	52	Des Moines
14	Pittsburgh	53	Kansas City
15	Newark	54	Omaha
21	Atlanta	55	St. Louis
22	Charlotte	61	Dallas
23	Philadelphia	62	Houston
24	Jacksonville	63	Memphis
25	Richmond	64	New Orleans
26	Washington	65	Oklahoma City
31	Cincinnati	71	Los Angeles
32	Cleveland	72	San Jose
33	Detroit	73	Salt Lake City
34	Indianapolis	74	Seattle
35	Lansing	75	Phoenix
36	Louisville	81	Ford of Canada
41	Chicago	83	Government
42	Fargo	84	Home Office Reserve
43	Milwaukee	85	American Red Cross
44	Twin Cities	89	Transportation
		90's	Export

Fig. 17—District Codes

P1142-A

CODE	RATIO AND RATING	CODE	RATIO AND RATING	CODE	RATIO AND RATING
05...Ford	4.11-3.3M ①	62...Rockwell F-106NX6	6.20-15M ①	C4...Dana #44	4.09-3.3M ①
08...Ford	3.50-3.3M ①	64...Rockwell F-106NX6	6.80-15M ①	C5...Dana #60-2	4.10-3.3M ①
09...Ford	3.70-3.3M ①	66...Rockwell F-106NX6	7.20-15M ①	F7...Eaton 13802	5.83/8.11-15M ①
17...Ford	3.25-3.3M ①	71...Rockwell H-140	5.87-17M ①	F8...Eaton 13802	6.33/8.81-15M ①
22...Dana #70	4.83-7.4M ①	72...Eaton 1414	5.57-17M ①	G2...Eaton 16802	5.57/7.75-17M ①
23...Dana #70	5.13-7.4M ①	73...Eaton 1614	6.50-17M ①	G3...Eaton 13802	6.50/9.04-17M ①
24...Dana #60	4.10-5.2M ①	74...Rockwell H-140	6.80-17M ①	Q4...Rockwell L346	6.39/8.78-18.5M ①
25...Dana #60	4.56-5.2M ①	75...Eaton 1614	7.17-17M ①	Q5...Rockwell L346	6.65/9.13-18.5M ①
26...Dana #60	4.83-5.2M ①	76...Rockwell H-140	7.20-17M ①	Q6...Rockwell L346	7.10/9.76-18.5M ①
29...Dana #70	5.87-7.4M ①	A8...Dana #44	3.54-3.3M ①	7H...Eaton 17800	6.50/8.87-18.5M ①
30...Rockwell C-100N	5.29-11M ①	A9...Dana #60-2	3.54-3.3M ①	8H...Eaton 17800	7.17/9.77-18.5M ①
32...Rockwell C-100N	6.20-11M ①	B4...Dana #60	4.10-5.2M ①	7Q...Eaton 1790A	6.50-18.5M ①
34...Rockwell C-100N	6.80-11M ①	B5...Dana #60	4.56-5.2M ①	8Q...Eaton 1790A	7.17-18.5M ①
41...Rockwell D-100WXT	5.83-13M ①	B6...Dana #60	4.88-5.2M ①	9Q...Eaton 1790A	7.67-18.5M ①
42...Rockwell D-100NXT	6.20-13M ①	C1...Dana #44	3.31-3.3M ①		
44...Rockwell D-100NXT	6.80-13M ①	C2...Dana #44	3.73-3.3M ①		

① Pounds Capacity in Thousands

Fig. 18—Rear Axle Codes -100 -750 and P-Series

P1138-A

<p>EATON 34 DP</p> <table border="1"> <thead> <tr> <th>Code</th> <th>Ratio and Rating</th> </tr> </thead> <tbody> <tr><td>1N</td><td>5.05-34M ①</td></tr> <tr><td>2N</td><td>5.60-34M ①</td></tr> <tr><td>3N</td><td>5.91-34M ①</td></tr> <tr><td>4N</td><td>6.21-34M ①</td></tr> <tr><td>5N</td><td>6.65-34M ①</td></tr> <tr><td>6N</td><td>7.60-34M ①</td></tr> <tr><td>7N</td><td>8.38-34M ①</td></tr> </tbody> </table>	Code	Ratio and Rating	1N	5.05-34M ①	2N	5.60-34M ①	3N	5.91-34M ①	4N	6.21-34M ①	5N	6.65-34M ①	6N	7.60-34M ①	7N	8.38-34M ①	<p>EATON 38 DS</p> <table border="1"> <thead> <tr> <th>Code</th> <th>Ratio and Rating</th> </tr> </thead> <tbody> <tr><td>11</td><td>4.56-38M ①</td></tr> <tr><td>21</td><td>4.88-38M ①</td></tr> <tr><td>31</td><td>5.57-38M ①</td></tr> <tr><td>41</td><td>6.14-38M ①</td></tr> <tr><td>51</td><td>6.50-38M ①</td></tr> </tbody> </table>	Code	Ratio and Rating	11	4.56-38M ①	21	4.88-38M ①	31	5.57-38M ①	41	6.14-38M ①	51	6.50-38M ①	<p>EATON 1919</p> <table border="1"> <thead> <tr> <th>Code</th> <th>Ratio and Rating</th> </tr> </thead> <tbody> <tr><td>1G</td><td>4.11-23M ①</td></tr> <tr><td>2G</td><td>4.33-23M ①</td></tr> <tr><td>3G</td><td>4.88-23M ①</td></tr> <tr><td>4G</td><td>5.43-23M ①</td></tr> <tr><td>5G</td><td>6.17-23M ①</td></tr> <tr><td>6G</td><td>6.67-23M ①</td></tr> </tbody> </table>	Code	Ratio and Rating	1G	4.11-23M ①	2G	4.33-23M ①	3G	4.88-23M ①	4G	5.43-23M ①	5G	6.17-23M ①	6G	6.67-23M ①		
Code	Ratio and Rating																																													
1N	5.05-34M ①																																													
2N	5.60-34M ①																																													
3N	5.91-34M ①																																													
4N	6.21-34M ①																																													
5N	6.65-34M ①																																													
6N	7.60-34M ①																																													
7N	8.38-34M ①																																													
Code	Ratio and Rating																																													
11	4.56-38M ①																																													
21	4.88-38M ①																																													
31	5.57-38M ①																																													
41	6.14-38M ①																																													
51	6.50-38M ①																																													
Code	Ratio and Rating																																													
1G	4.11-23M ①																																													
2G	4.33-23M ①																																													
3G	4.88-23M ①																																													
4G	5.43-23M ①																																													
5G	6.17-23M ①																																													
6G	6.67-23M ①																																													
<p>EATON 34 DS</p> <table border="1"> <tbody> <tr><td>1F</td><td>4.11-34M ①</td></tr> <tr><td>2F</td><td>4.33-34M ①</td></tr> <tr><td>3F</td><td>4.56-34M ①</td></tr> <tr><td>4F</td><td>4.88-34M ①</td></tr> <tr><td>5F</td><td>5.29-34M ①</td></tr> <tr><td>6F</td><td>5.57-34M ①</td></tr> <tr><td>7F</td><td>6.14-34M ①</td></tr> <tr><td>8F</td><td>6.50-34M ①</td></tr> <tr><td>9F</td><td>7.17-34M ①</td></tr> <tr><td>0F</td><td>7.60-34M ①</td></tr> </tbody> </table>	1F	4.11-34M ①	2F	4.33-34M ①	3F	4.56-34M ①	4F	4.88-34M ①	5F	5.29-34M ①	6F	5.57-34M ①	7F	6.14-34M ①	8F	6.50-34M ①	9F	7.17-34M ①	0F	7.60-34M ①	<p>EATON 42 DP</p> <table border="1"> <tbody> <tr><td>1V</td><td>7.60-44M ①</td></tr> <tr><td>2V</td><td>8.38-44M ①</td></tr> </tbody> </table>	1V	7.60-44M ①	2V	8.38-44M ①	<p>EATON 19801</p> <table border="1"> <tbody> <tr><td>1P</td><td>4.33/5.89-23M ①</td></tr> <tr><td>2P</td><td>4.88/6.63-23M ①</td></tr> <tr><td>3P</td><td>5.43/7.39-23M ①</td></tr> <tr><td>4P</td><td>6.17/8.40-23M ①</td></tr> <tr><td>5P</td><td>6.67/9.08-23M ①</td></tr> </tbody> </table>	1P	4.33/5.89-23M ①	2P	4.88/6.63-23M ①	3P	5.43/7.39-23M ①	4P	6.17/8.40-23M ①	5P	6.67/9.08-23M ①										
1F	4.11-34M ①																																													
2F	4.33-34M ①																																													
3F	4.56-34M ①																																													
4F	4.88-34M ①																																													
5F	5.29-34M ①																																													
6F	5.57-34M ①																																													
7F	6.14-34M ①																																													
8F	6.50-34M ①																																													
9F	7.17-34M ①																																													
0F	7.60-34M ①																																													
1V	7.60-44M ①																																													
2V	8.38-44M ①																																													
1P	4.33/5.89-23M ①																																													
2P	4.88/6.63-23M ①																																													
3P	5.43/7.39-23M ①																																													
4P	6.17/8.40-23M ①																																													
5P	6.67/9.08-23M ①																																													
<p>EATON 34 M</p> <table border="1"> <tbody> <tr><td>1E</td><td>4.56-34M ①</td></tr> <tr><td>2E</td><td>5.85-34M ①</td></tr> <tr><td>3E</td><td>6.69-34M ①</td></tr> <tr><td>4E</td><td>7.80-34M ①</td></tr> <tr><td>5E</td><td>8.60-34M ①</td></tr> </tbody> </table>	1E	4.56-34M ①	2E	5.85-34M ①	3E	6.69-34M ①	4E	7.80-34M ①	5E	8.60-34M ①	<p>EATON 38 DP</p> <table border="1"> <tbody> <tr><td>1R</td><td>5.05-38M ①</td></tr> <tr><td>2R</td><td>5.60-38M ①</td></tr> <tr><td>3R</td><td>5.91-38M ①</td></tr> <tr><td>4R</td><td>6.21-38M ①</td></tr> <tr><td>5R</td><td>6.65-38M ①</td></tr> <tr><td>6R</td><td>7.60-38M ①</td></tr> <tr><td>7R</td><td>8.38-38M ①</td></tr> </tbody> </table>	1R	5.05-38M ①	2R	5.60-38M ①	3R	5.91-38M ①	4R	6.21-38M ①	5R	6.65-38M ①	6R	7.60-38M ①	7R	8.38-38M ①	<p>EATON 9503</p> <table border="1"> <tbody> <tr><td>1X</td><td>5.89-23M ①</td></tr> <tr><td>2X</td><td>6.63-23M ①</td></tr> </tbody> </table>	1X	5.89-23M ①	2X	6.63-23M ①																
1E	4.56-34M ①																																													
2E	5.85-34M ①																																													
3E	6.69-34M ①																																													
4E	7.80-34M ①																																													
5E	8.60-34M ①																																													
1R	5.05-38M ①																																													
2R	5.60-38M ①																																													
3R	5.91-38M ①																																													
4R	6.21-38M ①																																													
5R	6.65-38M ①																																													
6R	7.60-38M ①																																													
7R	8.38-38M ①																																													
1X	5.89-23M ①																																													
2X	6.63-23M ①																																													
<p>EATON 34 DTA</p> <table border="1"> <tbody> <tr><td>1W</td><td>4.11/5.61-34M ①</td></tr> <tr><td>2W</td><td>4.33/5.91-34M ①</td></tr> <tr><td>3W</td><td>4.56/6.21-34M ①</td></tr> <tr><td>4W</td><td>4.88/6.65-34M ①</td></tr> <tr><td>5W</td><td>5.57/7.60-34M ①</td></tr> <tr><td>6W</td><td>6.14/8.38-34M ①</td></tr> <tr><td>7W</td><td>6.50/8.87-34M ①</td></tr> <tr><td>8W</td><td>7.17/9.77-34M ①</td></tr> </tbody> </table>	1W	4.11/5.61-34M ①	2W	4.33/5.91-34M ①	3W	4.56/6.21-34M ①	4W	4.88/6.65-34M ①	5W	5.57/7.60-34M ①	6W	6.14/8.38-34M ①	7W	6.50/8.87-34M ①	8W	7.17/9.77-34M ①	<p>EATON 22M</p> <table border="1"> <tbody> <tr><td>1A</td><td>6.70-22M ①</td></tr> <tr><td>2A</td><td>7.79-22M ①</td></tr> </tbody> </table>	1A	6.70-22M ①	2A	7.79-22M ①	<p>EATON 8802-3</p> <table border="1"> <tbody> <tr><td>1J</td><td>5.91-22M ①</td></tr> <tr><td>2J</td><td>6.21-22M ①</td></tr> <tr><td>3J</td><td>6.65-22M ①</td></tr> </tbody> </table>	1J	5.91-22M ①	2J	6.21-22M ①	3J	6.65-22M ①																		
1W	4.11/5.61-34M ①																																													
2W	4.33/5.91-34M ①																																													
3W	4.56/6.21-34M ①																																													
4W	4.88/6.65-34M ①																																													
5W	5.57/7.60-34M ①																																													
6W	6.14/8.38-34M ①																																													
7W	6.50/8.87-34M ①																																													
8W	7.17/9.77-34M ①																																													
1A	6.70-22M ①																																													
2A	7.79-22M ①																																													
1J	5.91-22M ①																																													
2J	6.21-22M ①																																													
3J	6.65-22M ①																																													
<p>EATON 30 D-3</p> <table border="1"> <tbody> <tr><td>3S</td><td>4.63/5.53/6.43-32M ①</td></tr> <tr><td>4S</td><td>4.88/5.83/6.77-32M ①</td></tr> <tr><td>5S</td><td>5.57/6.66/7.75-32M ①</td></tr> <tr><td>6S</td><td>6.14/7.35/8.55-32M ①</td></tr> <tr><td>7S</td><td>6.50/7.77/9.04-32M ①</td></tr> </tbody> </table>	3S	4.63/5.53/6.43-32M ①	4S	4.88/5.83/6.77-32M ①	5S	5.57/6.66/7.75-32M ①	6S	6.14/7.35/8.55-32M ①	7S	6.50/7.77/9.04-32M ①	<p>EATON 1790-A-91A</p> <table border="1"> <tbody> <tr><td>1Q</td><td>4.33-18.5M ①</td></tr> <tr><td>2Q</td><td>4.56-18.5M ①</td></tr> <tr><td>3Q</td><td>4.88-18.5M ①</td></tr> <tr><td>4Q</td><td>5.29-18.5M ①</td></tr> <tr><td>5Q</td><td>5.57-18.5M ①</td></tr> <tr><td>6Q</td><td>6.14-18.5M ①</td></tr> <tr><td>7Q</td><td>6.50-18.5M ①</td></tr> <tr><td>8Q</td><td>7.17-18.5M ①</td></tr> <tr><td>9Q</td><td>7.67-18.5M ①</td></tr> </tbody> </table>	1Q	4.33-18.5M ①	2Q	4.56-18.5M ①	3Q	4.88-18.5M ①	4Q	5.29-18.5M ①	5Q	5.57-18.5M ①	6Q	6.14-18.5M ①	7Q	6.50-18.5M ①	8Q	7.17-18.5M ①	9Q	7.67-18.5M ①	<p>EATON 30 DP</p> <table border="1"> <tbody> <tr><td>1D</td><td>6.43-32M ①</td></tr> <tr><td>2D</td><td>6.78-32M ①</td></tr> <tr><td>3D</td><td>7.75-32M ①</td></tr> <tr><td>4D</td><td>8.55-32M ①</td></tr> </tbody> </table>	1D	6.43-32M ①	2D	6.78-32M ①	3D	7.75-32M ①	4D	8.55-32M ①								
3S	4.63/5.53/6.43-32M ①																																													
4S	4.88/5.83/6.77-32M ①																																													
5S	5.57/6.66/7.75-32M ①																																													
6S	6.14/7.35/8.55-32M ①																																													
7S	6.50/7.77/9.04-32M ①																																													
1Q	4.33-18.5M ①																																													
2Q	4.56-18.5M ①																																													
3Q	4.88-18.5M ①																																													
4Q	5.29-18.5M ①																																													
5Q	5.57-18.5M ①																																													
6Q	6.14-18.5M ①																																													
7Q	6.50-18.5M ①																																													
8Q	7.17-18.5M ①																																													
9Q	7.67-18.5M ①																																													
1D	6.43-32M ①																																													
2D	6.78-32M ①																																													
3D	7.75-32M ①																																													
4D	8.55-32M ①																																													
<p>EATON 34 D-3</p> <table border="1"> <tbody> <tr><td>1T</td><td>5.11/4.86/5.61-34M ①</td></tr> <tr><td>2T</td><td>4.33/5.12/5.91-34M ①</td></tr> <tr><td>3T</td><td>4.56/5.39/6.21-34M ①</td></tr> <tr><td>4T</td><td>4.88/5.76/6.65-34M ①</td></tr> <tr><td>5T</td><td>5.57/6.59/7.60-34M ①</td></tr> <tr><td>6T</td><td>6.14/7.25/8.87-34M ①</td></tr> <tr><td>7T</td><td>6.14/7.26/8.38-34M ①</td></tr> </tbody> </table>	1T	5.11/4.86/5.61-34M ①	2T	4.33/5.12/5.91-34M ①	3T	4.56/5.39/6.21-34M ①	4T	4.88/5.76/6.65-34M ①	5T	5.57/6.59/7.60-34M ①	6T	6.14/7.25/8.87-34M ①	7T	6.14/7.26/8.38-34M ①	<p>EATON 17800-01</p> <table border="1"> <tbody> <tr><td>1H</td><td>4.33/5.91-18.5M ①</td></tr> <tr><td>2H</td><td>4.56/6.21-18.5M ①</td></tr> <tr><td>3H</td><td>4.88/6.65-18.5M ①</td></tr> <tr><td>4H</td><td>5.29/7.21-18.5M ①</td></tr> <tr><td>5H</td><td>5.57/7.60-18.5M ①</td></tr> <tr><td>6H</td><td>6.14/8.38-18.5M ①</td></tr> <tr><td>7H</td><td>6.50/8.87-18.5M ①</td></tr> <tr><td>8H</td><td>7.17/9.77-18.5M ①</td></tr> </tbody> </table>	1H	4.33/5.91-18.5M ①	2H	4.56/6.21-18.5M ①	3H	4.88/6.65-18.5M ①	4H	5.29/7.21-18.5M ①	5H	5.57/7.60-18.5M ①	6H	6.14/8.38-18.5M ①	7H	6.50/8.87-18.5M ①	8H	7.17/9.77-18.5M ①	<p>EATON 30 DS</p> <table border="1"> <tbody> <tr><td>1C</td><td>4.63-32M ①</td></tr> <tr><td>2C</td><td>4.88-32M ①</td></tr> <tr><td>3C</td><td>5.57-32M ①</td></tr> <tr><td>4C</td><td>6.14-32M ①</td></tr> <tr><td>5C</td><td>6.50-32M ①</td></tr> <tr><td>6C</td><td>7.17-32M ①</td></tr> <tr><td>7C</td><td>7.60-32M ①</td></tr> </tbody> </table>	1C	4.63-32M ①	2C	4.88-32M ①	3C	5.57-32M ①	4C	6.14-32M ①	5C	6.50-32M ①	6C	7.17-32M ①	7C	7.60-32M ①
1T	5.11/4.86/5.61-34M ①																																													
2T	4.33/5.12/5.91-34M ①																																													
3T	4.56/5.39/6.21-34M ①																																													
4T	4.88/5.76/6.65-34M ①																																													
5T	5.57/6.59/7.60-34M ①																																													
6T	6.14/7.25/8.87-34M ①																																													
7T	6.14/7.26/8.38-34M ①																																													
1H	4.33/5.91-18.5M ①																																													
2H	4.56/6.21-18.5M ①																																													
3H	4.88/6.65-18.5M ①																																													
4H	5.29/7.21-18.5M ①																																													
5H	5.57/7.60-18.5M ①																																													
6H	6.14/8.38-18.5M ①																																													
7H	6.50/8.87-18.5M ①																																													
8H	7.17/9.77-18.5M ①																																													
1C	4.63-32M ①																																													
2C	4.88-32M ①																																													
3C	5.57-32M ①																																													
4C	6.14-32M ①																																													
5C	6.50-32M ①																																													
6C	7.17-32M ①																																													
7C	7.60-32M ①																																													
<p>EATON 38 D-3</p> <table border="1"> <tbody> <tr><td>1Z</td><td>4.11/4.86/5.61-38M ①</td></tr> <tr><td>2Z</td><td>4.33/5.12/5.91-38M ①</td></tr> <tr><td>3Z</td><td>4.56/5.39/6.21-38M ①</td></tr> <tr><td>4Z</td><td>4.88/5.76/6.65-38M ①</td></tr> <tr><td>5Z</td><td>5.57/6.59/7.60-38M ①</td></tr> <tr><td>6Z</td><td>6.14/7.26/8.38-38M ①</td></tr> <tr><td>7Z</td><td>6.50/7.68/8.87-38M ①</td></tr> </tbody> </table>	1Z	4.11/4.86/5.61-38M ①	2Z	4.33/5.12/5.91-38M ①	3Z	4.56/5.39/6.21-38M ①	4Z	4.88/5.76/6.65-38M ①	5Z	5.57/6.59/7.60-38M ①	6Z	6.14/7.26/8.38-38M ①	7Z	6.50/7.68/8.87-38M ①	<p>EATON 1880-1</p> <table border="1"> <tbody> <tr><td>1K</td><td>4.88-22M ①</td></tr> <tr><td>2K</td><td>5.57-22M ①</td></tr> <tr><td>3K</td><td>6.14-22M ①</td></tr> <tr><td>4K</td><td>6.50-22M ①</td></tr> <tr><td>5K</td><td>7.17-22M ①</td></tr> </tbody> </table>	1K	4.88-22M ①	2K	5.57-22M ①	3K	6.14-22M ①	4K	6.50-22M ①	5K	7.17-22M ①	<p>EATON 30 DTA</p> <table border="1"> <tbody> <tr><td>1L</td><td>4.63/6.43-32M ①</td></tr> <tr><td>2L</td><td>4.88/6.77-32M ①</td></tr> <tr><td>3L</td><td>5.57/7.75-32M ①</td></tr> <tr><td>4L</td><td>6.14/8.54-32M ①</td></tr> <tr><td>5L</td><td>6.50/9.04-32M ①</td></tr> <tr><td>6L</td><td>7.17/9.77-32M ①</td></tr> </tbody> </table>	1L	4.63/6.43-32M ①	2L	4.88/6.77-32M ①	3L	5.57/7.75-32M ①	4L	6.14/8.54-32M ①	5L	6.50/9.04-32M ①	6L	7.17/9.77-32M ①								
1Z	4.11/4.86/5.61-38M ①																																													
2Z	4.33/5.12/5.91-38M ①																																													
3Z	4.56/5.39/6.21-38M ①																																													
4Z	4.88/5.76/6.65-38M ①																																													
5Z	5.57/6.59/7.60-38M ①																																													
6Z	6.14/7.26/8.38-38M ①																																													
7Z	6.50/7.68/8.87-38M ①																																													
1K	4.88-22M ①																																													
2K	5.57-22M ①																																													
3K	6.14-22M ①																																													
4K	6.50-22M ①																																													
5K	7.17-22M ①																																													
1L	4.63/6.43-32M ①																																													
2L	4.88/6.77-32M ①																																													
3L	5.57/7.75-32M ①																																													
4L	6.14/8.54-32M ①																																													
5L	6.50/9.04-32M ①																																													
6L	7.17/9.77-32M ①																																													
	<p>EATON 18802-3</p> <table border="1"> <tbody> <tr><td>1B</td><td>4.33/5.91-22M ①</td></tr> <tr><td>2B</td><td>4.56/6.21-22M ①</td></tr> <tr><td>3B</td><td>4.88/6.65-22M ①</td></tr> <tr><td>4B</td><td>5.57/7.60-22M ①</td></tr> <tr><td>5B</td><td>6.14/8.38-22M ①</td></tr> <tr><td>6B</td><td>6.50/8.87-22M ①</td></tr> <tr><td>7B</td><td>7.17/9.77-22M ①</td></tr> </tbody> </table>	1B	4.33/5.91-22M ①	2B	4.56/6.21-22M ①	3B	4.88/6.65-22M ①	4B	5.57/7.60-22M ①	5B	6.14/8.38-22M ①	6B	6.50/8.87-22M ①	7B	7.17/9.77-22M ①	<p>EATON 13802</p> <table border="1"> <tbody> <tr><td>F7</td><td>5.83/8.11-15M ①</td></tr> <tr><td>F8</td><td>6.33/8.81-15M ①</td></tr> </tbody> </table>	F7	5.83/8.11-15M ①	F8	6.33/8.81-15M ①																										
1B	4.33/5.91-22M ①																																													
2B	4.56/6.21-22M ①																																													
3B	4.88/6.65-22M ①																																													
4B	5.57/7.60-22M ①																																													
5B	6.14/8.38-22M ①																																													
6B	6.50/8.87-22M ①																																													
7B	7.17/9.77-22M ①																																													
F7	5.83/8.11-15M ①																																													
F8	6.33/8.81-15M ①																																													
		<p>EATON 1614-15</p> <table border="1"> <tbody> <tr><td>72</td><td>5.57-17M ①</td></tr> <tr><td>73</td><td>6.50-17M ①</td></tr> <tr><td>75</td><td>7.17-17M ①</td></tr> </tbody> </table>	72	5.57-17M ①	73	6.50-17M ①	75	7.17-17M ①																																						
72	5.57-17M ①																																													
73	6.50-17M ①																																													
75	7.17-17M ①																																													

① Pounds Capacity in Thousands.

Fig. 19—Rear Axle Codes -700 -1000 Series

EATON 16802-3		ROCKWELL C-100		ROCKWELL SQHD	
Code	Ratio and Rating	Code	Ratio and Rating	Code	Ratio and Rating
G2	5.57/7.75-17M ①	32	6.20-11M ①	D1	4.11-38M ①
G3	6.50/9.04-17M ①	34	6.80-11M ①	D2	4.44-38M ①
ROCKWELL Q246P		ROCKWELL D-100		D3	4.63-38M ①
L1	4.92-22M ①	41	5.83-13M ①	D4	5.91-38M ①
L2	5.63-22M ①	42	6.20-13M ①	D5	5.83-38M ①
L3	6.04-22M ①	44	6.80-13M ①	D6	6.83-38M ①
L4	6.39-22M ①	ROCKWELL F-106		D7	7.80-38M ①
L5	7.27-22M ①	62	6.3-15M ①	D8	8.60-38M ①
ROCKWELL Q346P		64	6.8-15M ①	ROCKWELL SQHD (w/Lt. Wt. Susp.)	
T1	4.92/6.76-22M ①	66	7.2-15M ①	M1	4.11-38M ①
T2	5.63/7.73-22M ①	ROCKWELL H-140		M2	4.44-38M ①
T3	6.00/8.24-22M ①	71	5.83-17M ①	M3	4.63-38M ①
T4	6.39/8.78-22M ①	74	6.80-17M ①	M4	5.29-38M ①
T5	7.33/10.07-22M ①	76	7.20-17M ①	M5	5.83-38M ①
ROCKWELL RT-241P		ROCKWELL SRDD		M6	6.83-38M ①
P1	4.62-23M ①	V1	7.54-44M ①	M7	7.80-38M ①
P2	4.99-23M ①	V2	8.31-44M ①	M8	8.60-38M ①
P3	5.46-23M ①	ROCKWELL SUDD		ROCKWELL SQDD	
P4	6.10-23M ①	A1	7.98-50M ①	Z1	7.54-38M ①
P5	7.21-23M ①	A2	9.00-50M ①	Z2	8.31-38M ①
ROCKWELL RT-341P		ROCKWELL SFDD		ROCKWELL R-171P	
X1	4.68/5.88-23M ①	J1	8.07-60M ①	H1	4.11-23M ①
X2	5.06/6.35-23M ①	J2	9.03-60M ①	H2	4.33-23M ①
X3	5.34/6.71-23M ①	J3	10.16-60M ①	H3	4.63-23M ①
X4	6.18/7.76-23M ①	ROCKWELL SLHD		H4	4.88-23M ①
X5	7.01/8.80-23M ①	B1	4.11-34M ①	H5	5.29-23M ①
ROCKWELL R-202P		B2	4.44-34M ①	H6	5.86-23M ①
ø1	4.41-23M ①	B3	4.63-34M ①	H7	6.14-23M ①
ø2	4.77-23M ①	B4	4.88-34M ①	H8	6.83-23M ①
ø3	5.54-23M ①	B5	5.29-34M ①	ROCKWELL SLHD (w/Lt. Wt. Susp.)	
ø4	6.26-23M ①	B6	5.83-34M ①	K1	4.11-34M ①
ø5	7.09-23M ①	B7	6.17-34M ①	K2	4.44-34M ①
ROCKWELL R-302P		B8	6.83-34M ①	K3	4.63-34M ①
Y1	4.41/5.64-23M ①	B9	7.80-34M ①	K4	4.88-34M ①
Y2	4.89/6.23-23M ①	B0	8.60-34M ①	K5	5.29-34M ①
Y3	5.54/7.09-23M ①	ROCKWELL SLDD		K6	5.83-34M ①
Y4	6.42/8.38-23M ①	N1	4.88-34M ①	K7	6.17-34M ①
Y5	7.09/9.07-23M ①	N2	5.29-34M ①	K8	6.83-34M ①
ROCKWELL L-346		N3	5.83-34M ①	K9	7.80-34M ①
Q1	4.96/6.76-18.5M ①	N4	6.17-34M ①	K0	8.60-34M ①
Q2	5.63/7.73-18.5M ①	N5	6.83-34M ①	ROCKWELL L-346	
Q3	6.00/8.24-18.5M ①	N6	7.67-34M ①	Q1	4.96/6.76-18.5M ①
Q4	6.39/8.78-18.5M ①	N7	8.44-34M ①	Q2	5.63/7.73-18.5M ①
Q5	6.65/9.13-18.5M ①	① Pounds Capacity in Thousands.		Q3	6.00/8.24-18.5M ①
Q6	7.10/9.76-18.5M ①			Q4	6.39/8.78-18.5M ①
				Q5	6.65/9.13-18.5M ①
				Q6	7.10/9.76-18.5M ①

Fig. 20—Rear Axle Codes -700 -1000 Series (Cont'd.)

Brakes

GROUP
2

PART 2-1	PAGE	PART 2-5	PAGE
General Brake Service	2- 1	Air-Hydraulic Booster	2-61
PART 2-2		PART 2-6	
Hydraulic Brakes.....	2-14	Air Supply System	2-67
PART 2-3		PART 2-7	
Parking Brakes	2-33	Air Brakes	2-74
PART 2-4		PART 2-8	
Vacuum Boosters	2-42	Specifications	2-97

PART 2 -1 - General Brake Service

Section	Page	Section	Page
1 Diagnosis and Testing.....	2-1	Brake Drum Repair 250 through 1000	
Hydraulic Brakes.....	2-1	Series Except 4-Wheel Drive—Front	2-4
Preliminary Tests – Power Brakes.....	2-2	Brake Drum Refinishing.....	2-5
Vacuum Tests	2-2	Brake Shoe Relining.....	2-5
Hydraulic Pressure Test.....	2-2	3 Cleaning and Inspection.....	2-5
Air Supply System	2-2	Brake Cylinder	2-5
Air Hydraulic Brakes.....	2-3	Master Cylinder.....	2-6
Air Brakes.....	2-4	Brake Drums and Linings.....	2-6
2 Common Adjustments and Repairs.....	2-4	Brake Booster	2-6
Brake Pedal Adjustment.....	2-4	Cam-Type Air Brakes.....	2-6
		Bendix Wedge-Type Air Brakes.....	2-6

1 DIAGNOSIS AND TESTING

Hydraulically operated service brakes are standard equipment on all 100 through 800 Series and on some 850 and 950 Series Ford trucks.

The standard hydraulic brake system on some trucks is assisted by a vacuum booster which may be installed as either standard or optional equipment. Other vehicles use an op-

tional compressed air booster (air-hydraulic unit) to provide a power assist to the hydraulic brakes. Service information on these two booster units is given in Parts 2-4 and 2-5.

The full air brake system, optional on some models and standard on most 850 through 1000 models, is covered in Part 2-7.

HYDRAULIC BRAKES

The trouble-diagnosis symptoms, causes, and corrections given under Diagnosis Guide-Standard Hydraulic Brakes, apply to all truck hydraulic brakes including those with a vacuum booster or an air-hydraulic unit.

PRELIMINARY CHECKS

Push the brake pedal down as far as it will go. If the pedal travels more than halfway between the released position and the floor, adjust the brakes.

Road test the vehicle and apply the brakes at a speed of about 20 mph to see if the truck stops evenly. If not, the brakes should be adjusted. **Perform the road test only when the brakes will apply and the vehicle can be safely stopped.**

PRELIMINARY TESTS—POWER BRAKES

With the engine stopped, eliminate all vacuum from the system by pumping the brake pedal several times. Then push the pedal down as far as it will go, and note the effort required to hold it in this position. If the pedal gradually moves downward under this pressure, the hydraulic system is leaking and should be checked by a hydraulic pressure test.

With the brake pedal still pushed down, start the engine. If the vacuum system is operating properly, the pedal will move downward. If the pedal position does not change, the vacuum system is not operating properly and should be checked by a vacuum test.

VACUUM TESTS

CHECK VALVE TEST

Disconnect the line from the bottom of the vacuum check valve, and connect a vacuum gauge to the valve. Start the engine, run it at idle speed, and check the reading on the vacuum gauge.

The gauge should register 17-19 inches with standard transmission and 14-15 inches in Drive range if equipped with an automatic transmission. Stop the engine and note the rate of vacuum drop. If the vacuum drops more than one inch in 15 seconds, the check valve is leaking. If the vacuum reading does not reach 18 inches or is unsteady, an engine tune-up is needed.

Remove the gauge and reconnect the vacuum line to the check valve.

BOOSTER TEST—BENDIX PISTON TYPE

Disconnect the vacuum line from the booster end plate. Install a tee fitting in the end plate, and connect a vacuum gauge (No. 1) and the vacuum line to

the fitting. Install a second vacuum gauge (No. 2) in place of the pipe plug in the booster control valve body.

Start the engine, and note the vacuum reading on both gauges. If both gauges do not register manifold vacuum, air is leaking into the vacuum system. If both gauges register manifold vacuum, stop the engine and note the rate of vacuum drop on both gauges. If the drop exceeds one inch in 15 seconds on either gauge, air is leaking into the vacuum system. Tighten all vacuum connections and repeat the test. If leakage still exists, the leak may be localized as follows:

1. Disconnect the vacuum line and gauge No. 1 from the booster.

2. Connect vacuum gauge No. 1 directly to the vacuum line. Start the engine and note the gauge reading. Stop the engine and check the rate of vacuum drop. If gauge No. 1 does not register manifold vacuum, or if the vacuum drop exceeds 1 inch in 15 seconds, the leak is in the vacuum line or check valve connections.

3. Reconnect vacuum gauge No. 1 and the vacuum line to the tee fitting. Start the engine, and run it at idle speed for one minute. Depress the brake pedal sufficiently to cause vacuum gauge No. 2 to read from zero to 1 inch of vacuum. Gauge No. 1 should register manifold vacuum of 17-19 inches with standard transmission and 14-16 inches in Drive range if equipped with an automatic transmission. If the drop of vacuum on gauge No. 2 is slow, the air cleaner, or air cleaner line, may be plugged. Inspect and clean the air cleaner if necessary.

4. Release the brake pedal and observe the action of gauge No. 2. Upon releasing the pedal, the vacuum gauge must register increasing vacuum until manifold vacuum is reached. The rate of increase must be smooth, with no lag or slowness in the return to manifold vacuum. If the gauge readings are not as outlined, the booster is not operating properly and should be removed and overhauled.

BOOSTER TEST—MIDLAND DIAPHRAGM TYPE (FRAME-MOUNTED)

Remove the pipe plug from the rear half of the booster chamber, and install a vacuum gauge. Start the engine and run it at idle speed. The gauge should register 18-21 inches of vacuum.

1. With the engine running, depress the brake pedal with enough pressure

to show a zero reading on the vacuum gauge. Hold the pedal in the applied position for one minute. Any downward movement of the pedal during this time indicates a brake fluid leak. Any kickback (upward movement) of the pedal indicates brake fluid is leaking past the hydraulic piston check valve.

2. With the engine running, push down on the brake pedal with sufficient pressure to show a zero reading on the vacuum gauge. Hold the pedal down, and shut the engine off. Maintain pedal position for one minute. A kickback of the pedal indicates a vacuum leak in the vacuum check valve, in the vacuum line connections, or in the booster.

HYDRAULIC PRESSURE TEST

Connect a 2000-psi hydraulic pressure gauge to a bleeder screw opening at one of the brake cylinders. **Bleed the air from the hydraulic system at the point of attachment of the gauge.**

Remove the pipe plug from the rear of the booster body or the trailer brake control line port, and connect a vacuum gauge at this point. With the engine running, apply the brakes enough to obtain a zero reading on the vacuum gauge. Then, note the reading on the pressure gauge. The minimum hydraulic pressure for each type and side of vacuum booster is given in Part 2-8. **If the engine vacuum is higher or lower than 20 inches Hg, the vacuum booster hydraulic pressure will be proportionately higher or lower than the pressure given in Part 2-8.**

Hold the brakes in the fully-applied position for at least one minute, and note the reading on the pressure gauge. The hydraulic system should hold pressure for at least one minute without losing pressure. A low pressure reading or a drop in pressure, indicates leakage in the booster or in the hydraulic system.

AIR SUPPLY SYSTEM

The same air supply system is used with either the air booster brake system (Part 2-5) or the full air brake system (Part 2-7). In the air booster system, air pressure increases or boosts the hydraulic pressure applied to the shoes. In the full air system, air pressure is applied directly to the shoes through a diaphragm and mechanical linkage.

If either of these two brake systems is not operating properly, the air sup-

ply system should be checked first.

OPERATING TESTS

Before performing any of the following tests, operate the engine until the air pressure builds up to 90 psi. With the air brake system charged, open the drain cocks in each reservoir. Close the drain cocks after all moisture is drained from the reservoirs.

Low Pressure Indicator

Exhaust the brake system pressure and observe the pressure at which the warning buzzer sounds. The contacts in the indicator should close the circuit to the buzzer, when reservoir pressure is between 54 psi minimum and 66 psi maximum. If the buzzer does not start to sound within this pressure range during discharge, or if a sounding buzzer does not stop within this pressure range during the pressure build-up, the electrical connections are loose or the indicator valve is defective.

Reservoir Safety Valve

To determine if the safety valve is operative, pull the exposed end of the valve stem. If the safety valve does not "blow off" when the stem is pulled, the valve ball is probably stuck in its seat. In such a case, remove and disassemble the valve for cleaning.

Governor

With the engine running, build up air pressure in the system, and observe at what pressure reading on the dash gauge the pressure stops climbing. This is the point of governor cutout which should be between 100 and 105 pounds.

With the engine still running, slowly reduce the air pressure in the system by applying and releasing the brakes. Observe the pressure reading on the dash gauge at the point where the pressure starts to build up again. This is the point of governor cut-in which should be between 80 and 85 pounds.

If the governor does not cut the compressor in and out according to these specifications, adjust the governor pressure settings. Before adjusting the governor, check the accuracy of the dash gauge with a test gauge.

Check Pressure Build-Up

With the engine running at fast idle speed, observe the time required to

raise system pressure from 50 to 90 pounds. If more than five minutes is required, perform the leak tests as outlined in the following paragraphs.

Also check for no unloading valve clearance, low engine idle speed, a slipping compressor drive belt, excessive carbon in the compressor cylinder head, or a worn out air compressor.

LEAK TESTS

Compressor

With the engine stopped, discharge valve leakage can be detected by carefully listening at the compressor for the sound of escaping air. With air pressure applied to the unloader cavity (with governor cut-out), remove the air filter or the air pick up tube on SD V-8 engines and check for air leaks by squirting oil around the unloader plunger and stem. If excessive air leaks are found, replace the unloader piston seal.

Governor

With the governor in the cutout position, test for leakage at the exhaust valve by applying soap suds to the exhaust vent in the body.

With the governor in the cut-in position, test for leakage of the inlet valve by applying soap suds to the exhaust vent in the body.

In either of the foregoing tests, leakage in excess of 1-inch soap bubble in three seconds indicates a defective governor.

Coat the entire governor with soap suds to detect diaphragm, gasket, and cap screw leakage. No leakage is permissible.

Reservoir Safety Valve

Coat the end of the safety valve with soap suds. Leaks causing not more than a 3-inch soap bubble in three seconds are permissible.

AIR-HYDRAULIC BRAKES

The trouble diagnosis procedures given here apply only to the booster unit and the applicable air system components.

First make the trouble diagnosis checks outlined under Hydraulic Brakes and Air Supply System. Then perform the tests outlined in the following paragraphs.

OPERATING TESTS

Air Discharge Test

With the air pressure at 90 psi, depress the brake pedal several times and listen for air discharge as the pedal is released. Rapid release of air pressure indicates that the booster unit is operating. If no air discharge is heard, the booster control valve is defective or the connecting lines are restricted.

Air Leak Test

Operate the engine until the air pressure builds up to 90 psi. Stop the engine and watch the pressure gauge. If the air pressure drops more than 5 pounds in 15 seconds, check for internal leaks in the system, particularly at hose or pipe connections, a defective valve or piston in the booster, a defective air gauge (registering incorrectly), or leaking governor or compressor discharge valves.

Hydraulic Pressure Test

Connect a hydraulic pressure gauge (capable of reading at least 1200 psi pressure) to a bleeder screw opening at one of the brake cylinders.

Remove the lubrication pipe plug from the rear of the booster body assembly and connect an air pressure test gauge at this point. Apply the brakes until approximately 60 psi is registered on the air gauge. Note the reading on the hydraulic pressure gauge. Hydraulic pressure should be 950 to 1100 psi when air pressure is at 60 psi. If air pressure is higher or lower than 60 psi, hydraulic pressure will be proportionately higher or lower than 950 to 1100 psi.

Hold the brakes in the fully applied position for at least one minute. Note the reading on the hydraulic pressure gauge. A low pressure reading, or a drop in pressure indicates leakage in the booster unit or in the other hydraulic system components.

Booster Test

With the air pressure at 90 psi, depress the brake pedal. Measure and record the distance from the pedal to the floor.

Release the pedal and bleed all the air from the system. Depress the pedal, and again measure the distance from the pedal to the floor. The second measurement should be approximately 1/2 inch more than the dimension-

obtained with the booster system operating under air pressure. If there is no noticeable difference in the measurements, the booster is defective.

AIR BRAKES

Some of the air brake system components vary slightly from one truck model to another in design or location. However, all components are essentially the same in principle and service procedure.

First make the trouble diagnosis checks outlined under Air Supply System, and then perform the tests outlined in the following paragraphs.

OPERATING TESTS

Check Stop Light Switch

With all air pressure exhausted from the air brake system, start the engine and move the brake valve to the applied position. Stop lights should light before the dash gauge registers 10 psi pressure. Release the brakes.

Quick Release Valve and Relay Valve

With the air brake system fully charged, apply the brakes. Inspect the brake action on the wheels controlled by the quick release valve or relay valve in question. The brakes should apply promptly. Release the brakes and inspect to be sure that the air pressure is exhausted rapidly from the exhaust port. Be sure the exhaust port is not restricted.

LEAK TESTS

With the engine stopped and the brakes fully applied, watch the rate of drop in air pressure as registered by the dash gauge. If the pressure drops faster than 3 pounds per minute, check the items outlined in the following paragraphs.

Brake Valve

With the pedal fully released, coat the exhaust port with soap suds to check for leaks. With the pedal fully applied, coat the exhaust port with soap suds and check for leaks. Leaks

causing not more than a three inch soap bubble in three seconds are permissible.

Brake Chambers

With the brakes fully applied, coat the clamp ring and bolt flanges holding the diaphragm in place with soap suds. No leaks are permissible.

Quick Release Valve

With brakes applied, coat the exhaust port with soap suds to detect leakage. Leakage in excess of a 3-inch soap bubble in three seconds is not permissible.

Relay Valve

With the brakes released, coat the exhaust port with soap suds and observe the leakage.

With the brakes fully applied, coat the exhaust port with soap suds and observe the leakage.

Leakage in either of the foregoing tests should not exceed a 3 inch soap bubble in three seconds.

2 COMMON ADJUSTMENTS AND REPAIRS

BRAKE PEDAL ADJUSTMENT

In order to release the brakes, fluid in a hydraulic brake system must flow back to the master cylinder when pedal pressure is released. A port is provided in the master cylinder to allow this flow, but the piston must move back far enough to expose the return port. To be sure that this will always happen, free-travel is built into the pedal linkage on standard and on frame-mounted booster systems. This free-travel prevents the piston from becoming trapped in a partially released position. Pedal free travel is not always perceptible in dash-mounted booster systems, however, because the operating clearance for the piston is adjusted at the booster push-rod, rather than the pedal linkage. (Refer to Part 2-4 for instructions on dash-mounted booster push-rod adjustments).

If the pedal free travel in a standard hydraulic brake system or frame mounted hydraulic booster system is less than 3/16 inch or more than 3/8 inch (Fig. 1), the pedal should be adjusted.

To adjust free-travel:

1. Push the brake pedal down by hand pressure, and check the free travel.

2. Loosen the lock nut on the eccentric bolt, and rotate the eccentric bolt until the free travel is within 3/16-3/8 inch.

On a P-Series truck, turn the hex head of the push rod to obtain the required free-travel.

3. Hold the bolt securely, and torque the lock nut to 30-35 ft-lbs.

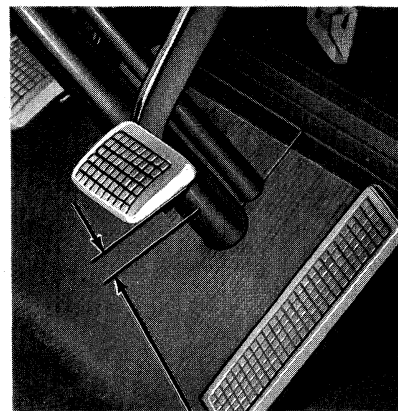

Fig. 1—Pedal Free Travel Check

4. Recheck the pedal free-travel to make sure that the adjustment did not change when the lock nut was tightened.

BRAKE DRUM REPAIR 250 THROUGH 1000 SERIES EXCEPT 4-WHEEL DRIVE-FRONT

The service procedures covered here apply to both hydraulic and air brakes. Since the F-100 and P-100 (front and rear) and the 4-wheel drive front brake drum procedures apply to hydraulic brakes only, they are covered in Section 3 of Part 2-2.

Front Brake Drum

1. Raise the truck until the wheel and tire clear the floor and remove the wheel and tire from the hub. Back off the brake shoe adjusting screw so that the shoes do not contact the brake drum. Remove the grease cap and the gasket (if so equipped) from the hub.

2. With 4,000 through 7,000 lb. front axles remove the cotter pin, adjusting nut and flat washer from the spindle.

On trucks with a 9,000 lb. or 11,000 or 15,000 lb. axle, remove the lock nut, the dimpled washer, the locking ring and the adjusting nut and pin assembly.

3. Remove the outer bearing cone and roller. Pull the hub and drum assembly off the wheel spindle.

4. Remove the front wheel to hub retaining nuts or rim and tire attaching nuts. Remove the wheel or rim and tire from the hub and drum.

5. Remove the brake drum retainers and attaching bolts, screws, or bolts and nuts.

6. Remove the brake drum from the hub.

7. Check the drum for defects or wear, and repair or replace as necessary. If a new drum is to be installed, be sure to remove the protective coating with a suitable degreaser.

8. Place the brake drum to the hub and install the retainers and retaining bolts, screws, or bolts and nuts.

9. Install the hub and drum on the wheel spindle. **Keep the hub centered on the spindle to prevent damage to the grease retainer or the spindle threads.**

10. With 4,000 through 7,000 lb. front axles, install the outer bearing cone and roller and the flat washer on the spindle, then install the adjusting nut. With front axles of 9,000 lbs., 11,000 or 15,000 lbs. capacity, install the outer bearing cone and roller and the bearing adjusting nut and pin assembly.

11. Install the wheel and tire on the hub, then install the clamps (cast type only), and the wheel stud nuts.

12. With 4,000 through 7,000 lb. front axles, torque the adjusting nut to specifications while rotating the wheel. Back off the adjusting nut at least one, but not more than two castellations (about 1/6 to 1/4 turn). Lock the adjusting nut in this position with a new cotter pin.

With 9,000 lb., 11,000 or 15,000 lb. axles, torque the adjusting nut to specifications while rotating the wheel. Back off the nut 1/4 to 1/3 turn, and install the locking ring. **Do not exceed the 1/4 to 1/3 turn if the adjusting nut must be moved to align the nut pin with a hole in the locking ring.**

Install the dimpled washer with the dimple indexed in one of the holes in the adjusting nut. Install the lock nut and torque to specifications. Bend the dimpled washer over a flat of the lock nut.

13. Install the gasket (if so equipped) and the grease cap, and torque the wheel stud nuts to specifications. Install the hub cap if so equipped, and adjust the brakes.

REAR BRAKE DRUM

1. Raise the truck and install stands.

2. Remove the wheel and tire as an assembly. Then back off the rear brake shoe adjustment.

3. Remove the rear axle shaft retaining nuts, adapters, axle shaft, and grease seal.

4. Remove the wheel bearing locknut, lock washer, and adjusting nut.

5. Remove the hub and drum from the axle.

6. Remove the brake drum to hub retaining screws, bolts, or bolts and nuts. Then remove the brake drum from the hub.

7. Check the drum for defects or wear, and repair or replace as necessary. If a new drum is to be installed, be sure to remove the protective coating with a suitable degreaser.

8. Position the brake drum to the hub and install the attaching screws, bolts, or bolts and nuts.

9. Position the hub and drum as an assembly on the axle and start the adjusting nut.

10. Adjust the wheel bearing nut and then install the wheel bearing lock washer and locknut.

11. Install a new rear axle oil seal, axle shaft and gasket, stud adapters, and attaching nuts.

12. Install the wheel and tire as an assembly.

13. Adjust the brake shoes and then remove the stand and lower the truck.

BRAKE DRUM REFINISHING

Minor scores on a brake drum can be removed with fine emery cloth, provided the emery is thoroughly

cleaned off the drum after the operation.

A badly scored, rough, or out-of-round drum should be ground or turned on a drum lathe. Do not remove any more material from the drum than is necessary to provide a smooth surface for the brake shoe contact. The refinished diameter should not be more than 0.060 inch oversize for steel backed composite drums and 0.090 for cast iron drums except F-100-F-350 full cast drum, which is 0.060 inch. For original brake drum sizes, see Part 2-8.

If the diameter of the drum is less than 0.030 inch oversize after refinishing, install standard linings on the brake assemblies. If the diameter is over 0.030 inch, install oversize or shimmed linings.

BRAKE SHOE RELINING

1. Remove the rivets and remove the old lining.

2. Clean the shoe thoroughly with cleaning fluid, especially the rim surface. Wipe the shoe dry and remove all burrs or rough spots from the shoe.

3. Check the inside diameter of the brake drum. If the diameter is less than 0.030 inch oversize, install standard linings. If the diameter is 0.030-0.060 inch oversize, install oversize or shimmed linings.

4. Position the new lining on the shoe and install new rivets, beginning with the rivet holes near the center of the shoe. On some vehicles, the primary lining is shorter than the secondary lining. If this condition exists, position the shorter (primary) lining to line up with the heel end of the shoe. **Do not let oil or grease touch the brake lining. If a brake lining kit is used to replace the worn linings, install all the parts supplied in the kit.**

5. Check the clearance between the lining and shoe rim. The lining must seat snugly against the rim with not more than 0.005 inch separation midway between any two rivets. If only the linings are replaced on duo-servo single anchor brakes with fixed anchor pins, the brake linings must be cam ground 0.010 inch at the ends after the linings are riveted to the brake shoe.

3 CLEANING AND INSPECTION

BRAKE CYLINDER

1. Clean all brake cylinder parts in

clean denatured alcohol. Inspect all parts for wear or damage. Check the cylinder bore for rust, scores, or other

damage. Be sure that the bleeder screw passage is clean and open. Replace all parts that are worn or damaged.

2. If dirt is found in any part of the hydraulic system, flush the entire system with clean denatured alcohol.

MASTER CYLINDER

1. Clean all master cylinder parts in clean denatured alcohol, and inspect the parts for wear or damage, replacing them as required. When a master cylinder repair kit is used, install all of the parts supplied in the kit.

2. Check the ports and vents in the master cylinder to make sure that all are open and free of foreign matter.

3. If the spring valve (riveted to the front end of the piston) is loose or has moved so that the piston ports are open, replace the piston.

4. Inspect the cylinder walls for scores or rust, and recondition them if necessary. Hone the cylinder walls no more than necessary (0.003 inch maximum), either to remove scores and rust, or to obtain a smooth wall surface. Remove any burrs or loose metal that may have resulted from the honing operation, and clean the cylinder with clean denatured alcohol.

BRAKE DRUMS AND LININGS

1. After removing one front wheel and drum from the truck, inspect the drum and brake shoe linings for wear or damage that would affect brake operation. Do not let oil or grease touch the drum or linings.

2. A brake shoe should be relined when the lining face is worn to within 1/32 inch of any rivet head, or when the lining has been soaked with oil or grease. If a worn lining is not replaced, the brake drum may become severely damaged. Always replace the primary and secondary brake shoe lining assemblies on both front or both rear brake assemblies at the same time.

3. Before relining a brake shoe, inspect the shoe for distortion, cracks, or looseness between the rim and web. If one of these conditions exists, replace the shoe. Do not attempt to repair a damaged brake shoe.

4. If the drum and linings are in good condition, install the wheel and drum. The condition of the drums and linings of the other three wheels will usually be about the same as that found at the wheel that was removed.

5. Add enough heavy-duty brake fluid to the master cylinder reservoir to bring the level to within 1/2 inch of the top of the filler neck.

6. Check to be sure that the parking brake handle is fully released before making any brake adjustment.

7. Check the front brake anchor pin nut with a wrench (on brake assemblies with an adjustable anchor pin). If the bolt is loose, torque it to 80-100 ft-lbs.

BRAKE BOOSTER

1. After disassembly, immerse all metal parts in a suitable solvent. Use only alcohol on rubber parts or parts containing rubber. After the parts have been thoroughly cleaned and rinsed in cleaning solvent, the metal parts which come in contact with hydraulic brake fluid should be rewashed in clean alcohol before assembly. Use an air hose to blow dirt and cleaning fluid from the recesses and internal passages. When overhauling a power booster, use all parts furnished in the repair kit. Discard all old rubber parts.

2. Inspect all other parts for damage or excessive wear. Replace damaged or excessively worn parts. If the inside of the booster body is rusted or corroded, polish it with steel wool or fine emery cloth. Replace the body shell when scored. Inspect the master cylinder bore for signs of scoring, rust, pitting or etching. Any of these conditions will require replacement of the cylinder.

CAM-TYPE AIR BRAKES

1. Inspect the camshaft bushings and replace if worn or damaged.

2. Check the anchor pins and shoe-to-cam rollers for wear or damage, and replace, if required.

3. Check thickness of the brake lining at the center of the shoe, and replace, if necessary.

4. Clean, inspect, and replace worn or damaged parts. Coat the anchor pins and cam lobes with Lubriplate before installing the shoes.

BENDIX WEDGE-TYPE AIR BRAKES

Clean the metal parts in a non-oily solvent. Replace the rubber parts whenever the brake is disassembled. Replace damaged or worn metal parts. Do not use gasoline or hot water solutions on metal parts.

Inspect the following parts and replace defective pieces:

Wedge

Check rod and wedge surfaces for scoring.

Plungers

Check outside surface for scoring. On anchoring plungers, check shoe web slot for roughness.

Adjusting Screw and Nut

Check for sheared threads. Check adjuster ring teeth for wear.

Link

Check shoe web slot for roughness and cracks.

Rollers

Check for score marks and cracks.

Spring Clip

Check clip for fatigue cracks.

Automatic Adjustment Lever and Spring

Inspect for broken spring. Check lever for fatigue cracks and distortion.

Overload Spring

Inspect spring for fatigue cracks. Replace if test load is less than 13 lb when spring ends are compressed 1/2 inch apart.

Actuator Casting (Torque Spider)

Inspect machined bores for roughness. Use emery cloth to remove any rough areas which interfere with plunger movement. Check automatic adjuster pin for corrosion or distortion. Check the shoe guide bosses and steady rest for roughness on the rubbing surfaces. Inspect the mountring and holes of torque spider for cracks.

INSPECTION OF ADJUSTER

Clean all metal parts in a non-oily solvent. Replace all damaged or worn parts, and whenever the brake is disassembled, replace all rubber parts. Coat all threads and bearing surfaces of links with Bendix Special Brake Lubricant or brick Lubriplate. Use same lubricant on plunger and also dip spring and lever in light oil. Check and refinish bores, if necessary, with crocus cloth or hone.

<p>BRAKES DO NOT APPLY</p>	<p>If the brake pedal travels all the way down to the floor without noticeable brake action, check the brake fluid level in the master cylinder reservoir. Refill the reservoir if necessary. Check the entire hydraulic system for fluid leaks, and make the necessary adjustments.</p> <p>If the brake pedal feels spongy when pushed down, air has entered the hydraulic lines. Air can enter the lines if the fluid level in the master cylinder reservoir is too low, or if the brake wheel cylinder pistons are not held firmly in place when the brake</p>	<p>shoes are serviced. A defective check valve can cause a loss of residual pressure in the system causing air to enter at the wheel cylinder piston. Bleed the system to remove air from the lines, and adjust the brakes. Refill the master cylinder reservoir with heavy-duty brake fluid. If the brakes do not apply after making these checks and adjustments, fluid may be leaking past the piston cups in the master cylinder or brake wheel cylinder(s). If the trouble is in the master cylinder or brake wheel cylinder(s), remove and repair.</p>
<p>EXCESSIVE PEDAL TRAVEL</p>	<p>Check for air in the brake lines and bleed the system if necessary. Ad-</p>	<p>just or reline the brakes as needed.</p>
<p>UNEVEN NOISY, GRABBING, OR HARD OPERATING BRAKES</p>	<p>Remove the brake drums so that a complete inspection of the brake assemblies can be made to determine the cause of the trouble.</p> <p>Excessive dust and dirt in the brake lining rivet holes or in the brake drum can cause brake squeal. Remove the dirt with a scraper and an air hose.</p> <p>Drums which are out-of-round or loose at the hub; frozen master cylinder or brake cylinder piston(s); defective check valve; improper brake shoe</p>	<p>adjustment; warped or mis-aligned shoes; webs glazed or greasy linings; and incorrectly ground or wrong linings, are a few of the causes for uneven, noisy, pulling, grabbing, or hard brakes. Adjust or replace the parts as needed to eliminate the trouble. Lining glaze can be removed by rubbing the lining with medium-grade sandpaper until the lining has a dull finish. Always adjust the brakes after correcting any of these brake troubles.</p>
<p>BRAKES DO NOT RELEASE</p>	<p>Check for an improperly adjusted brake pedal, a restricted by-pass port in the master cylinder, or swollen master cylinder piston cups. Check for a defective check valve restricting fluid passing through the system. Check for sticking brake cylinder pistons caused by dirty or contaminated brake fluid.</p> <p>Adjust the brake pedal if necessary. If the adjustment does not correct the trouble, check the condition of the brake fluid. Replace dirty or contam-</p>	<p>inated fluid. Clean the entire hydraulic system with clean denatured alcohol before adding new brake fluid.</p> <p>If the trouble is in the master cylinder, remove and rebuild the cylinder.</p> <p>If the truck must be moved when the brakes are locked, open a brake cylinder bleeder screw for a moment to let out a few drops of brake fluid. This operation will release the brakes but will not eliminate the cause of the trouble.</p>

Fig. 2—Diagnosis Guide – Standard Hydraulic Brakes

H-1438-A

BOOSTER INOPERATIVE— HARD PEDAL	<p>The trouble may be caused by vacuum leakage. Disconnect the vacuum line at the booster, remove the vacuum manifold and check valve assembly, and look for a sticking or faulty check valve. Check all vacuum connections for leakage or obstruction. Check all hoses for a leaking or collapsed condition. Repair or replace parts as necessary.</p> <p>If the foregoing procedure does not eliminate the trouble, remove the</p>	<p>booster from the car. Separate the front shell from the rear shell, and check the valve and rod assembly reaction disc, diaphragm plate, and diaphragm assembly for damage that would cause leaks. When assembling, be sure that the diaphragm assembly is properly positioned. Improper location could cause leakage between the vacuum and atmospheric sides of the diaphragm.</p>
BRAKES DRAG OR GRAB	<p>The condition is probably caused by a sticking valve plunger assembly. Remove and disassemble the booster.</p>	<p>Clean, inspect, and replace parts as necessary.</p>
SELF APPLICATION OF BRAKES WHEN ENGINE STARTS	<p>Remove and disassemble the booster. Check for a leak in the rear shell. Check the diaphragm for being out of locating radii in the housing. Check</p>	<p>for a sticking or unseated valve poppet. Clean, inspect, and replace parts as necessary. Be sure that the diaphragm is properly located when assembling.</p>

H1439-A

Fig. 3—Diagnosis Guide – Power Brakes Vacuum Booster – Bendix Dash Mounted

BOOSTER INOPERATIVE HARD PEDAL	<p>Check as follows to see if the power unit is operating: With the engine stopped, depress the brake pedal several times to eliminate all vacuum from the system. Apply the brakes, and while maintaining pressure on the pedal, start the engine. If the unit is operating, the brake pedal will move forward slightly when engine vacuum power is added to the foot pressure on the pedal. If the unit is not operating, there will be no pedal action.</p> <p>If this check shows that the unit is not operating, check for the following:</p>	<p>Brake pedal linkage sticking. Faulty vacuum check valve. Collapsed or leaking vacuum hose. Plugged vacuum fittings. Leaking vacuum chamber. Vacuum check valve stuck in closed position. Leak in bellows assembly. Diaphragm assembly out of place in housing locating radii: Vacuum leak in automatic transmission T.V. vacuum line connection or fitting. Vacuum leak in forward, vacuum housing.</p>
BRAKES DRAG	<p>Sticking valve plunger.</p>	
BRAKES GRAB	<p>Sticking actuating valve assembly.</p>	
SELF APPLICATION OF BRAKES WHEN ENGINE STARTS	<p>Leak in rear housing. Diaphragm out of locating radii in housings and allowing atmospheric</p>	<p>pressure into rear chamber. Sticking or unseated atmospheric valve.</p>

H1440-A

Fig. 4—Diagnosis Guide – Power Brakes Vacuum Booster – Midland Dash Mounted

<p>BRAKE PEDAL KICKS BACK WHEN APPLIED</p>	<p>This condition may be caused by a defective hydraulic piston check valve or slave cylinder piston cup.</p>	<p>Replace the slave cylinder piston and/or piston cup.</p>
<p>ROUGH ENGINE IDLE WITH BRAKES RELEASED</p>	<p>Check for vacuum leaks in the vacuum line, loose hose connections, a loose body clamp, or a weak control valve piston return spring. Check all connections and tighten them or replace damaged parts as required.</p>	<p>This condition may also be caused by vacuum leaks at the control valve diaphragm, at the valve piston assembly, or at the power diaphragm. Remove and overhaul the booster assembly.</p>
<p>ROUGH ENGINE IDLE OR STALL AND HARD PEDAL WITH BRAKES APPLIED</p>	<p>Check the condition of the air cleaner. If it is clogged with dirt, replace the air cleaner felt. A sticking control valve piston, leaks at the control valve diaphragm or atmospheric valve seal, dirt on the control</p>	<p>valve plate, or the control valve piston not seating properly on the plate may also cause this condition. In addition, the booster diaphragm may be damaged. Remove and overhaul the booster assembly.</p>
<p>INTERMITTENT HARD BRAKE PEDAL</p>	<p>Check for an obstructed air cleaner, a defective vacuum check valve, or a slave cylinder piston sticking in the bore due to dirt or inferior hy-</p>	<p>draulic fluid. Clean or replace damaged parts, refill the hydraulic system with new heavy-duty type brake fluid, and bleed the system.</p>
<p>HARD PEDAL—BOOSTER DIAPHRAGM RUPTURED</p>	<p>When a ruptured diaphragm is found, check for gasoline odor on the diaphragm. Gasoline will deteriorate the diaphragm and cause a premature failure.</p>	<p>Gasoline can get on the diaphragm from the intake manifold if the vacuum check valve is defective or if hoses are not routed correctly.</p>
<p>BRAKES DO NOT RELEASE</p>	<p>Check the rear of the vacuum chamber for damage. This condition may also be caused by a sticking control valve piston, a faulty slave cylinder piston check valve, dirty brake fluid, a sticking slave cylinder piston, a sticking push rod, or a faulty check valve in the end cap. Remove and overhaul the booster. In case of emergency, if a sticking</p>	<p>control valve piston holds the brakes in an applied position, disconnect the booster vacuum line from the vacuum check valve and install a pipe plug in the check valve opening. This permits the brakes to release. Manual application of brakes may then be made without assistance from the booster.</p>

Fig. 5—Diagnosis Guide – Power Brakes Vacuum Boosters – Frame Mounted

H1441-A

<p>AIR PRESSURE BELOW NORMAL</p>	<p>Defective air gauge. Compressor worn out. Compressor discharge valve leakage. Slipping compressor drive belt. Open reservoir drain cock. Excessive leakage at lines and fittings to reservoir tank.</p>	<p>Low engine speed. Excessive carbon in the compressor head or discharge line. Clogged compressor air strainer. Defective or improperly adjusted governor. Compressor inlet valves stuck closed.</p>
<p>AIR PRESSURE RISES ABOVE NORMAL</p>	<p>Defective or improperly adjusted governor. Compressor unloading valves stuck closed. Restriction in the passage between the governor and the compressor unloading mechanism. Defective air gauge.</p>	<p>Excessive clearance at the compressor unloading valves. Leak at compressor unloading piston seal. Carbon deposits in cavities beneath unloading piston and passages in the compressor cylinder head.</p>
<p>CONTINUOUS OR INTERMITTENT COMPRESSOR KNOCKS</p>	<p>Loose drive pulley. Worn or burned out compressor bearings.</p>	<p>Excessive carbon deposits in the compressor cylinder head.</p>
<p>SAFETY VALVE "BLOWS-OFF"</p>	<p>Governor "cut-out" setting adjusted too high. Above normal system pressure.</p>	<p>Defective or improperly adjusted safety valve.</p>
<p>EXCESSIVE OIL OR WATER IN THE BRAKE SYSTEM</p>	<p>Failure to drain the reservoirs at regular intervals.</p>	<p>Worn compressor piston rings. Dirty compressor air filter.</p>

Fig. 6—Diagnosis Guide – Air Supply System

H1442-A

<p>BRAKES WILL NOT APPLY</p>	<p>Compressor not operating. Broken or disconnected air line. Defective brake applying valve in truck or in towing vehicle.</p>	<p>Defective emergency relay valve. (If trouble is in trailer brakes only.) Punctured diaphragm in air chamber.</p>
<p>BRAKES APPLY BUT BRAKING IS NOT ADEQUATE</p>	<p>Truck is overloaded. Compressor drive belt is slipping. Low air pressure in brake system due to leak in lines or fittings.</p>	<p>Leak at the air chambers. Glazed linings in the wheelbrakes. Brakes not properly adjusted. Brake drum broken or cracked.</p>
<p>BRAKES APPLY TOO SLOWLY</p>	<p>Low air pressure in system. Restricted air hose or tubing. Excessive air leakage in system. Defective brake applying valve in</p>	<p>truck or in towing vehicle. Defective emergency relay valve. (If trouble is in trailer brakes only.) Leak at air chambers.</p>
<p>BRAKES WILL NOT RELEASE</p>	<p>Defective brake applying valve in truck or towing vehicle. Two-way hand valve in towing vehicle is in emergency position. (If trouble is in trailer brakes only.)</p>	<p>Broken wedge return spring in brake actuator housing. Brake shoes adjusted too close to brake drum.</p>
<p>BRAKES RELEASE TOO SLOWLY</p>	<p>Defective brake applying valve in truck or towing vehicle. Restricted air line. Weak or broken brake shoe-to-shoe springs. Weak wedge return spring in actuator.</p>	<p>Shoe guide ledges dry or corroded. Binding of wedge actuating mechanism because of inadequate lubrication. Plungers corroded and frozen in cylinder bore.</p>
<p>GRABBY BRAKES OR UNEVEN BRAKING</p>	<p>Defective brake applying valve in truck or towing vehicle. Defective emergency relay valve. (If trouble is in trailer brakes only.) Grease on linings. Scored or braken brake drum. Distorted brake shoes.</p>	<p>Lining loose on shoes. Loose wheel bearing. Brake drum out-of-round. Binding of wedge actuating mechanism because of inadequate lubrication.</p>
<p>When trouble-diagnosing, investigate the entire system since braking problems may originate in many parts of the air brake system other than the basic wheel brakes.</p>		

Fig. 7-Diagnosis Guide – Wedge-Type Air Brakes

<p>LEAKING SPRING BRAKE (Air Pressure Loss)</p>	<p>Check air lines and connections. If air exhausts constantly from service brake port when spring brake has been charged with air, replace pushrod seal. If air exhausts constantly from</p>	<p>breather cap opening when spring brake has been charged with air, replace main seal. If air bubbles appear from under release bolt head, replace collar seal.</p>
<p>NO PARKING BRAKE</p>	<p>Spring brake is manually released. Screw in release bolt. Spring failure. Disassemble unit and replace spring. Service brake chamber piston rod not mated with wedge shaft.</p>	<p>Improper adjustment of wedge brakes. Check automatic adjuster mechanism for correct assembly and operation. Damaged or incorrectly assembled wedge brake. Check mechanism.</p>
<p>LEAKING SERVICE BRAKE AIR CHAMBER (Air Pressure Loss)</p>	<p>Check all lines and connections. Charge service brake chamber with air. Soap or oil test clamp ring. If bubbles appear, tighten clamp ring. If bubbles persist, replace diaphragm. If air exhausts constantly from</p>	<p>spring brake port when service brake chamber has been charged with air, replace pushrod seal. Examine diaphragm for wear, cracks or rupture. Replace, if necessary.</p>
<p>SPRING BRAKE WILL NOT RELEASE WITH AIR</p>	<p>Check air lines and connections. Insufficient air pressure being delivered to spring brake. Check pres-</p>	<p>sure at end of air line. Damaged or incorrectly assembled wedge brake. Check mechanism.</p>

Fig. 8—Diagnosis Guide – Air Parking and Safety Brake

H1444-A

<p>INSUFFICIENT BRAKING</p>	<p>Binding control valve piston due to swollen piston seals.</p>	<p>Defective hydraulic cylinder piston.</p>
<p>BRAKES APPLY TOO SLOWLY</p>	<p>Brake shoes improperly adjusted. Low system air pressure. Control valve delivery pressure too low.</p>	<p>Excessive air leakage when brakes are applied. Restricted brake lines or hoses.</p>
<p>BRAKES RELEASE TOO SLOWLY</p>	<p>Weak control valve piston return spring. Restricted control valve exhaust</p>	<p>port. Hydraulic piston binding in the cylinder.</p>
<p>BRAKES DO NOT APPLY</p>	<p>Restricted or broken lines or hoses. Clogged or damaged control valve.</p>	<p>Dented or damaged booster body.</p>
<p>BRAKES DO NOT RELEASE</p>	<p>Defective control valve piston. Defective hydraulic piston. Clogged master cylinder vent.</p>	<p>Broken booster piston return spring.</p>
<p>BRAKES GRAB</p>	<p>Intermittent bind in the control valve piston.</p>	

Fig. 9—Diagnosis Guide – Air Hydraulic Brakes

H1445-A

INSUFFICIENT BRAKING ACTION	<p>Low reservoir pressure. Brakes need lubrication, adjustment, or relining. Foot control valve delivery pres-</p>	<p>sure too low due to a malfunction in the valve or incorrect adjustment of the treadle linkage.</p>
SLOW BRAKE ACTION	<p>SLOW APPLICATION</p> <p>Lack of lubrication at brake shoe camshafts. Low reservoir pressure. Excessive leakage during brake application. Restricted or damaged pipes or hoses. Defective foot control valve and treadle linkage.</p>	<p>SLOW RELEASE</p> <p>Restricted port, weak return spring, or other defect in foot control valve. Brakes require lubrication or adjustment. Restricted or damaged pipes or hoses. Defective or restricted quick release valve or relay valve. Broken retraction springs or binding hold pins.</p>
BRAKES INOPERATIVE	<p>BRAKES DO NOT RELEASE</p> <p>Restricted brake lines. Weak return spring or other defect in foot control valve. Broken brake shoe retracting springs or rusted front anchor pins.</p>	<p>BRAKES DO NOT APPLY</p> <p>Low reservoir pressure. Restricted or broken pipes or hoses. Defective foot control valve.</p>
UNEVEN OR GRABBING BRAKES	<p>Grease on brake linings. Out-of-round brake drums. Bind in brake shoe mountings. Defective foot control valve. Wet brakes.</p>	<p>Brakes need adjustment, lubrication, or relining. Leaking brake chambers. Broken brake chamber piston return spring.</p>
QUICK AIR PRESSURE DROP WITH ENGINE STOPPED	<p>BRAKES RELEASED</p> <p>Excessive leakage at foot control valve, governor, compressor discharge valve, or at other points in the system.</p>	<p>BRAKES APPLIED</p> <p>Excessive leakage in brake chambers, brake chamber diaphragms, tube and hose connections, or foot control valve.</p>

H1446-A

Fig. 10—Diagnosis Guide – Cam-Type Air Brakes

PART 2-2- Hydraulic Brakes

Section	Page	Section	Page
1 Description and Operation	2-14	Brake Carrier Plate—F-100 and P-100 Series Trucks Except 4-Wheel Drive—Front	2-25
Self Adjusting Brakes	2-14	Brake Carrier Plate—Trucks with 4-Wheel Drive—Front.....	2-26
2 In-Vehicle Adjustments and Repairs	2-16	Brake Carrier Plate 350 through 950 Series Truck Except 4-Wheel Drive—Front	2-26
Brake Shoe Adjustment	2-16	Master Cylinder—B-, F-, N-, and T-Series Trucks	2-26
Hydraulic System Bleeding	2-18	Master Cylinder—P-Series Truck	2-27
Hydraulic Line Replacement	2-19	Master Cylinder—C-Series Truck.....	2-27
3 Removal and Installation	2-19	Brake Pedal—B-, F-, N-, or T-Series and P-100 Truck	2-28
Brake Drums—F-, P-100 and F-250 with Self Adjusting Brakes	2-19	Brake Pedal—P-Series Trucks Except P-100	2-28
Front Brake Drum—4-Wheel Drive Trucks	2-20	Brake Pedal—C-Series Truck	2-29
Brake Drums 250 Through 1000 Series Except 4-Wheel Drive—Front	2-20	4 Major Repair Operations	2-29
Brake Shoe and Adjusting Screw F- and P-100 Trucks Only	2-20	Brake Wheel Cylinder	2-29
Brake Shoe and Adjusting Screw F-250 Trucks	2-21	Master Cylinder	2-30
Single Anchor Brake Shoe.....	2-23	Master Cylinder—Trucks Equipped with a Dash-Mounted Booster.....	2-31
Two-Cylinder Brake Shoe—Front	2-23		
Two-Cylinder Brake Shoe—Rear	2-23		
Brake Wheel Cylinder	2-25		

1 DESCRIPTION AND OPERATION

Hydraulically operated service brakes (Fig. 1) are standard equipment on all 100 through 800 Series and on some 850 and 950 Series Ford trucks.

The standard hydraulic brake system on some trucks is assisted by a vacuum booster which may be installed as either standard or optional equipment. Other trucks use an optional compressed air booster (air-hydraulic unit) to provide a power assist to the hydraulic brakes.

The master cylinder converts physical force from the brake pedal and booster into hydraulic pressure against the pistons in the wheel cylinders. The wheel cylinder pistons in turn convert hydraulic pressure back into physical force at the brake shoes.

All Ford truck brakes have internal expanding shoes. The different types of brake assembly vary in the way that the shoes are anchored, in the number of wheel cylinders used at each wheel, and in the number of pistons in the wheel cylinder.

In the single anchor type, both brake shoes are mounted to the same anchor

and are actuated by one wheel cylinder. In the uni-servo, single anchor brake, the wheel cylinder has only one piston which exerts force against the upper end of the primary shoe (Fig. 16). In the duo-servo, single anchor brake, the wheel cylinder has two pistons. One piston exerts force against the upper end of the primary shoe; the other piston exerts force against the upper end of the secondary shoe (Figs. 2 and 3).

In the double anchor type, each shoe is mounted to a separate anchor. The shoes are actuated by one duo-servo (two piston) cylinder at the upper end.

The front wheels of some trucks are equipped with two cylinders, each having one piston (Fig. 17). The piston in one cylinder exerts force against one end of one shoe; the piston in the other cylinder exerts force against the opposite end of the other shoe.

The rear wheels of some trucks are equipped with two cylinders, each having two pistons (four pistons total). Each of the four pistons exerts force

against one end of one shoe (Figs. 18 and 19).

SELF ADJUSTING BRAKES

Single anchor duo servo type brake assemblies equipped with a self adjusting mechanism are used front and rear on F-100, P-100 and F-250 trucks. The F-250 self-adjusting brake differs from the brake used on the F- and P-100 and is not interchangeable.

F-100 AND P-100 TYPE

The self-adjusting brake mechanism consists of a cable, cable guide, adjusting lever, and adjuster spring (Fig. 2). The cable is hooked over the anchor pin at the top and is connected to the lever at the bottom. The cable is connected to the secondary brake shoe by means of the cable guide. The adjuster spring is hooked to the primary brake shoe and to the lever.

The automatic adjuster operates only while the truck is moving rear-

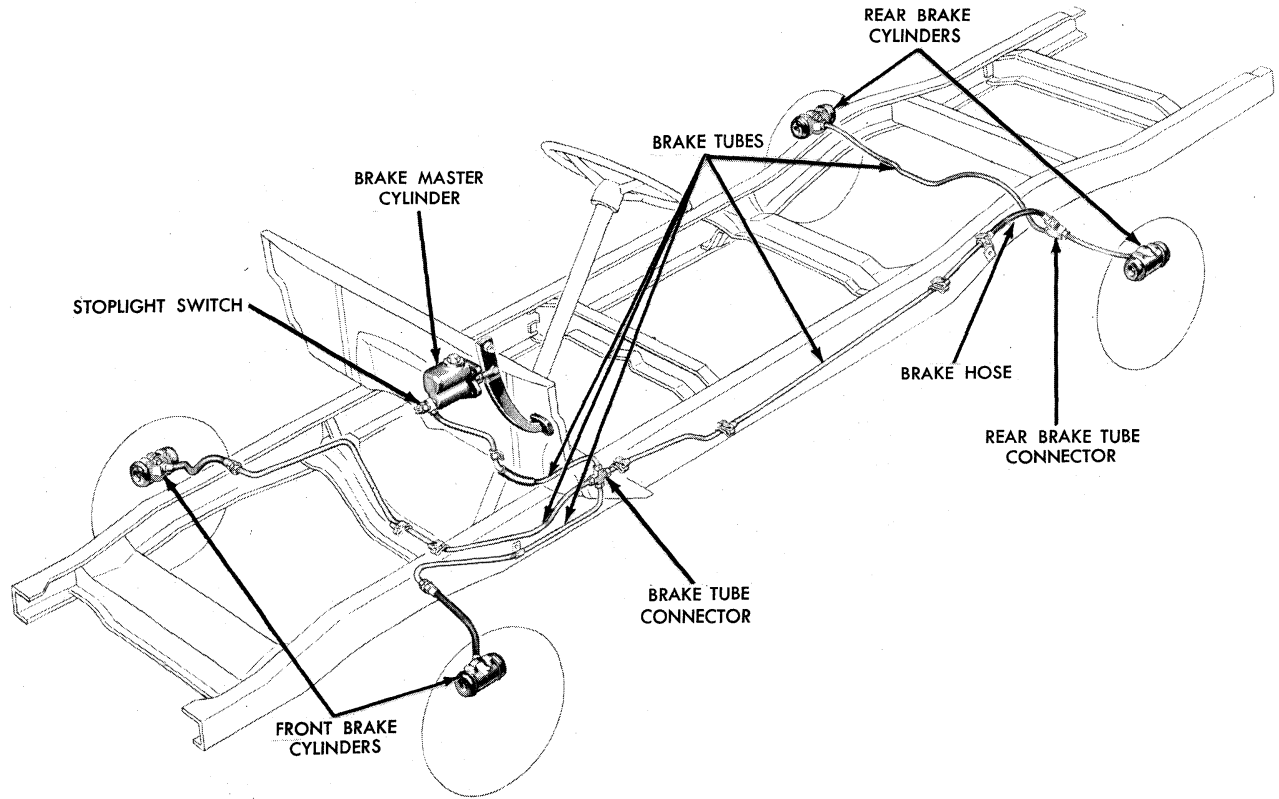

H1166-A

Fig. 1—Typical Hydraulic Brake System

ward and the brake pedal pressure is firmly applied.

With the truck moving rearward and the brakes applied, the “wrap-

around” action of the shoes following the drum forces the upper end of the primary shoe against the anchor pin. The action of the wheel cylinder moves

the upper end of the secondary shoe away from the anchor pin. The movement of the secondary shoe causes the cable to pull the adjusting lever up-

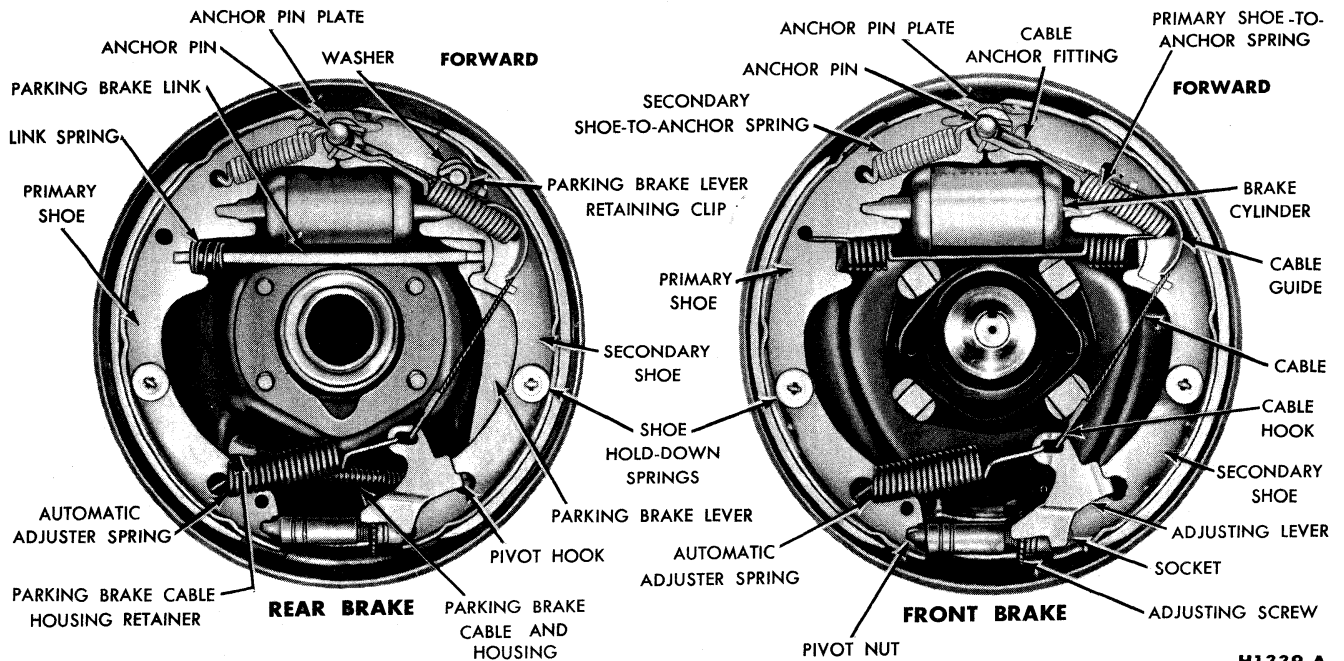

H1339-A

Fig. 2—Self Adjusting Brake Assemblies – F-100 Series

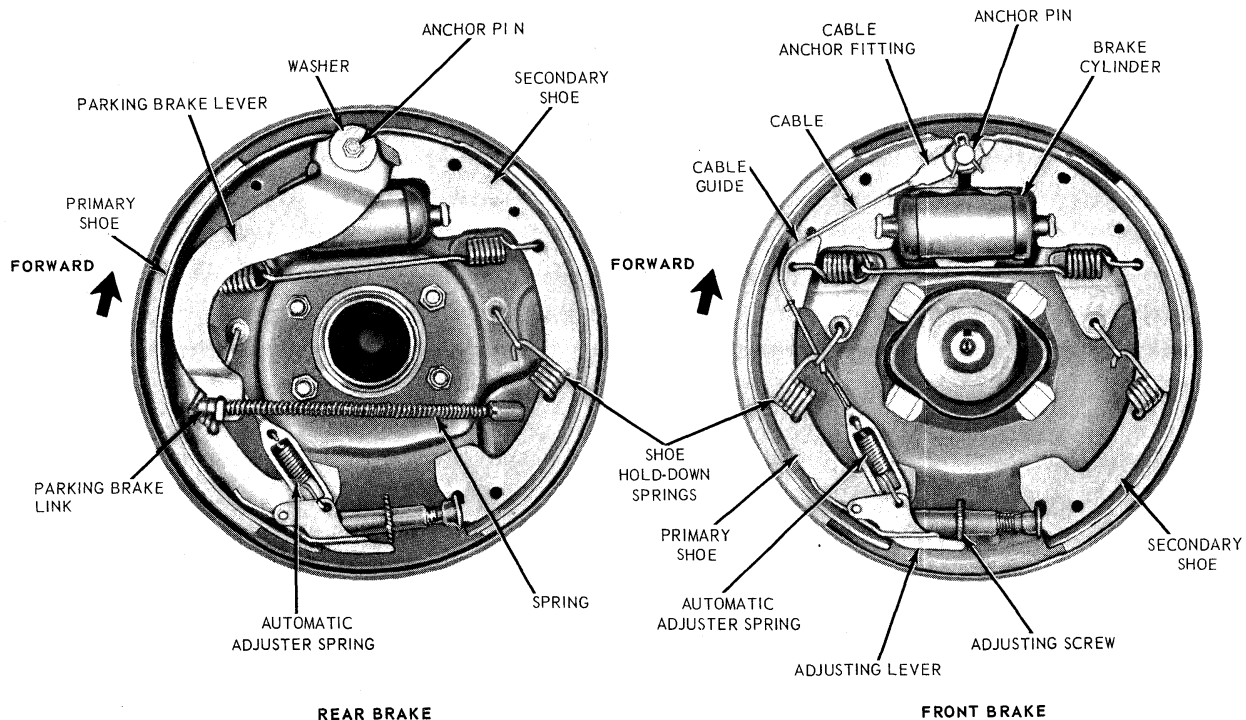

H1428 - A

Fig. 3—Self Adjusting Brake Assemblies – F-250 Series

ward and against the end of a tooth on the adjusting screw star-wheel. The upward travel of the lever increases as lining wear increases. When the lever can move upward far enough it passes over the end of the tooth and engages the tooth. When the brakes are released, the adjuster spring pulls the lever downward causing the starwheel to turn and expand the shoes. The starwheel is turned 1 tooth at a time as the linings progressively wear.

With the truck moving forward and the brakes applied, the secondary shoe

is against the anchor pin and the primary shoe is moved toward the drum. Therefore, the adjuster does not operate.

The rear brake assembly is basically the same as the front brake. The conventional parking brake lever, link, and spring are used in the rear brake.

The anchor pins on F- and P-100 brakes are fixed and non-adjustable.

F-250 TYPE

The self-adjusting brake used on the

F-250 is basically similar in operation to that used on the F- and P-100. However, the adjuster lever moves upward to turn the star- or ratchet-wheel, rather than downward as on the F-, P-100.

The parking brake operation differs from the F-, P-100 type brake. As can be seen in Fig. 3, a positive camming effect is applied directly to the brake shoes by the actuating lever bolted to the fixed anchor pin.

2 IN-TRUCK ADJUSTMENTS AND REPAIRS

BRAKE SHOE ADJUSTMENT

The brake drums should be at normal room temperature, when the brake shoes are adjusted. If the shoes are adjusted when the shoes are hot and expanded, the shoes may drag as the drums cool and contract.

A minor brake adjustment re-establishes the brake lining-to-drum clearance and compensates for normal lining wear.

A major brake adjustment includes

the adjustment of the brake shoe anchor pins, as well as the brake shoes. Adjustment of the anchor pin permits the centering of the brake shoes in the drum.

Adjustment procedures for each type of brake assembly are given under the applicable heading.

SELF ADJUSTING BRAKES

The brake shoes are automatically adjusted when the truck is driven in

reverse and the brakes applied. A manual adjustment is required only after the brake shoes have been relined or replaced. **The manual adjustment is performed while the drums are removed, using the tool and the procedure detailed below.**

When adjusting the rear brake shoes, check the parking brake cables for proper adjustment. Make sure that the equalizer operates freely.

To adjust the brake shoes:

1. Use Rotunda Tool HRE 8650,

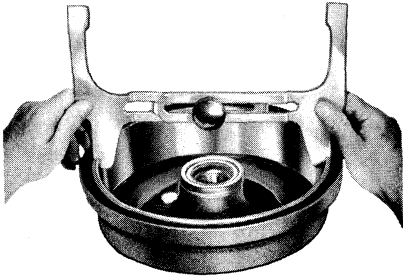

H 1411-A

Fig. 4—Measuring Drum

(Fig. 4) to determine the inside diameter of the drum braking surface.

2. Reverse the tool as shown in Fig. 5 and adjust the brake shoe diameter to fit the gauge. Hold the automatic adjusting lever out of engagement while rotating the adjusting screw, to prevent burring the screw slots. Make sure the adjusting screw rotates freely. If necessary, lubricate the adjusting screw threads with a thin, uniform coating of CIAZ-19590-B Grease.

3. Rotate Tool HRE 8650 around the brake shoes to be sure of the setting.

4. Apply a small quantity of high temperature grease to the points where the shoes contact the carrier plate, being careful not to get the lubricant on the linings.

5. Install the drums.

6. Install the wheels on the drums and tighten the mounting nuts to specification. Install Tinnerman nuts and tighten securely.

7. Complete the adjustment by applying the brakes several times while backing the vehicle.

8. After the brake shoes have been properly adjusted, check the operation of the brakes by making several stops while operating in a forward direction.

If a brake drum will not come off, insert a narrow screwdriver through the brake adjusting hole in the carrier plate, and disengage the adjusting lever

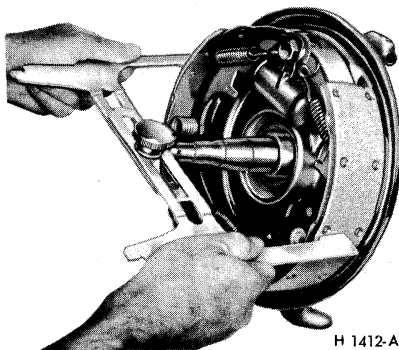

H 1412-A

Fig. 5—Measuring Shoes

from the adjusting screw. While thus holding the adjusting lever away from the adjusting screw, back off the adjusting screw with the brake adjusting tool (Fig. 11). **Back off the adjustment only if the drum cannot be removed. Be very careful not to burr, chip, or damage the notches in the adjusting screw; otherwise, the self adjusting mechanism will not function properly.**

SINGLE ANCHOR BRAKE

Minor Adjustment

The single anchor brake is adjusted by turning an adjusting screw located between the lower ends of the shoes.

1. Raise the truck until the wheels clear the floor.

2. Remove the cover from the adjusting hole at the bottom of the brake carrier plate, and turn the adjusting screw inside the hole to expand the brake shoes until they drag against the brake drum and lock up the drum. Back off the adjusting screw until a slight drag is noted. (Fig. 6).

3. When the shoes are against the drum, back off the adjusting screw 10 to 12 notches so that the drum rotates freely without drag. If the drum does not rotate freely, remove the wheel and drum, and then blow out the dust and dirt from the linings. With sandpaper, remove all rust from the points where the shoes contact the carrier plate and apply a light coating of high temperature grease. Be careful not to get the lubricant on the linings.

4. Install the wheel and drum, and adjust the shoes. Install the adjusting hole cover on the brake carrier plate.

5. Check and adjust the other three brake assemblies.

6. Apply the brakes. If the pedal

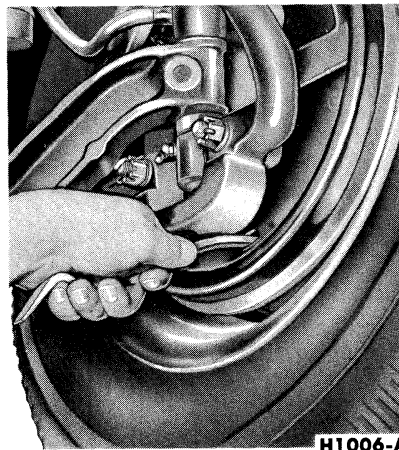

H1006-A

Fig. 6—Single Anchor Brake Shoe Adjustment

travels more than halfway down between the released position and the floor, too much clearance exists between the brake shoes and the drums. Repeat steps 2 and 3 above.

7. When all brake shoes have been properly adjusted, lower the truck. Road test the truck and check the operation of the brakes. **Perform the road test only when the brakes will apply and the truck can be safely stopped.**

Major Adjustment

(F-350 Rear Only) A major brake adjustment should be made on movable anchor brakes when dragging brakes are not corrected by a minor adjustment, when brake shoes are relined or replaced, or when brake drums are machined.

1. Raise the truck until the wheel clears the floor.

2. Rotate the drum until the feeler slot is opposite the lower end of the secondary (rear) brake shoe.

3. Insert a 0.010-inch feeler gauge through the slot in the drum. Move the feeler up along the secondary shoe until it is wedged between the secondary shoe and the drum.

4. Turn the adjusting screw (star wheel) to expand the brake shoes until a heavy drag is felt against the drum. Back off the adjusting screw just enough to establish a clearance of 0.010 inch, between the shoe and the drum at a point 1 1/2 inches from each end of the secondary shoe. This adjustment will provide correct operating clearance for both the primary and secondary shoes. If the 0.010-inch clearance cannot be obtained at both ends of the secondary shoe, the anchor pin must be adjusted.

5. To adjust the anchor pin setting, loosen the anchor pin nut just enough to permit moving the pin up or down

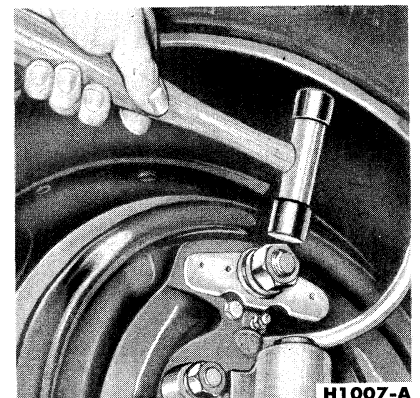

H1007-A

Fig. 7—Anchor Pin Adjustment