

1981 & 1982 MUSTANG / CAPRI

T-ROOF DIAGNOSIS AND SERVICE MANUAL

DEMO

This DEMO contains only a few pages of the entire manual/product.

Not all Bookmarks work on the Demo, but they do on the full version.

Features:

- Searchable text
- Printable pages
- Bookmarked for easy navigation
- High Resolution images
- Zoom to see exact details
- Money back Guarantee
- Transfer to USB flash drive support



Official
Licensed
Product

License #2013225



Ford Parts and Service Division
Training and Publications Department

Copyright © 2020, Forel Publishing Company, LLC, Woodbridge, Virginia

All Rights Reserved. No part of this book may be used or reproduced in any manner whatsoever without written permission of Forel Publishing Company, LLC. For information write to Forel Publishing Company, LLC, 3999 Peregrine Ridge Ct., Woodbridge, VA 22192

1981-1982 T-Roof Diagnosis and Service Manual (Mustang/Capri)

EAN: 978-1-60371-213-2

ISBN: 1-60371-213-5

Forel Publishing Company, LLC

3999 Peregrine Ridge Ct.

Woodbridge, VA 22192

Email address: sales@ForelPublishing.com

Website: <http://www.ForelPublishing.com>



This publication contains material that is reproduced and distributed under a license from Ford Motor Company. No further reproduction or distribution of the Ford Motor Company material is allowed without the express written permission of Ford Motor Company.

Acknowledgements

My sincere thanks to George Porubski of Perogie Enterprises for his help in locating and compiling this manual. Without his help and friendship this manual may never have made it to the public. My sincere thanks.

Note from the Publisher

This product was created from the original Ford Motor Company's publication. Every effort has been made to use the original scanned images, however, due to the condition of the material; some pages have been modified to remove imperfections.

Disclaimer

Although every effort was made to ensure the accuracy of this book, no representations or warranties of any kind are made concerning the accuracy, completeness or suitability of the information, either expressed or implied. As a result, the information contained within this book should be used as general information only. The author and Forel Publishing Company, LLC shall have neither liability nor responsibility to any person or entity with respect to any loss or damage caused, or alleged to be caused, directly or indirectly by the information contained in this book. Further, the publisher and author are not engaged in rendering legal or other professional services. If legal, mechanical, electrical, or other expert assistance is required, the services of a competent professional should be sought.

IMPORTANT SAFETY NOTICE

Appropriate service methods and proper repair procedures are essential for the safe, reliable operation of all motor vehicles, as well as the personal safety of the individual doing the work. This manual provides general directions for accomplishing service and repair work with tested, effective techniques. Following them will help assure reliability.

There are numerous variations in procedures, techniques, tools, and parts for servicing vehicles, as well as in the skill of the individual doing the work. This manual cannot possibly anticipate all such variations and provide advice or cautions as to each. Accordingly, anyone who departs from the instructions provided in this manual must first establish that he compromises neither his personal safety nor the vehicle integrity by his choice of methods, tools or parts.

As you read through the procedures, you will come across NOTES, CAUTIONS, AND WARNINGS. Each one is there for a specific purpose. NOTES give you added information that will help you to complete a particular procedure. CAUTIONS are given to prevent you from making an error that could damage the vehicle. WARNINGS remind you to be especially careful in those areas where carelessness can cause personal injury. The following list contains some general WARNINGS that you should follow when you work on a vehicle.

- Always wear safety glasses for eye protection.
- Use safety stands whenever a procedure requires you to be under the vehicle.
- Be sure that the ignition switch is always in the OFF position, unless otherwise required by the procedure.
- Set the parking brake when working on the vehicle. If you have an automatic transmission, set it in PARK unless instructed otherwise for a specific service operation. If you have a manual transmission, it should be in REVERSE (engine OFF) or NEUTRAL (engine ON) unless instructed otherwise for a specific service operation.
- Operate the engine only in a well-ventilated area to avoid the danger of carbon monoxide.
- Keep yourself and your clothing away from moving parts when the engine is running, especially the fan and belts.
- To prevent serious burns, avoid contact with hot metal parts such as the radiator, exhaust manifold, tail pipe, catalytic converter and muffler.
- Do not smoke while working on the vehicle.
- To avoid injury, always remove rings, watches, loose hanging jewelry, and loose clothing before beginning to work on a vehicle. Tie long hair securely behind the head.
- Keep hands and other objects clear of the radiator fan blades. Electric cooling fans can start to operate at any time by an increase in underhood temperatures, even though the ignition is in the OFF position. Therefore, care should be taken to ensure that the electric cooling fan is completely disconnected when working under the hood.

The recommendations and suggestions contained in this manual are made to assist the dealer in improving his dealership parts and/or service department operations. These recommendations and suggestions do not supersede or override the provisions of the Warranty and Policy Manual, and in any cases where there may be a conflict, the provisions of the Warranty and Policy Manual shall govern.

The descriptions, testing procedures, and specifications in this handbook were in effect at the time the handbook was approved for printing. Ford Motor Company reserves the right to discontinue models at any time, or change specifications, design or testing procedures without notice and without incurring obligation. Any reference to brand names in this manual is intended merely as an example of the types of tools, lubricants, materials, etc. recommended for use. Equivalents if available may be used. The right is reserved to make changes at any time without notice.

TABLE OF CONTENTS

DESCRIPTION OF T-ROOF SYSTEM	1	CORRECTIONS FOR HARD CLOSING DOOR	11
Weatherstrips	1	LEAKS IN ROOF HEADLINER	12
Roof Panel Assembly with Latches	1	Leaks in the Center of the Roof Along Center Bar	13
Door Glass Up-Stop	1	Water Enters Between Front or Rear Edge of Roof Frame and Roof Sheet Metal	13
Window Adjustments	1	Leaks Above Front Seats	14
Drain System	1	Leaks Coming Through Striker Area	15
DIAGNOSIS	4	WATER ENTERING DOOR GLASS	15
Initial Inspection	4	Water Enters At Butt Joints	16
Door Closing Effort	4	Water Enters Glass Over Seal at End of Drain Channel	17
Weatherstrip Condition And Fits	5	Water Enters Along "A" Pillar Near Sail Mirror	17
Door Window Operation	5	DOOR CAP REPLACEMENTS	18
WATER TEST PROCEDURES	7	PHASE II — DOOR REPLACEMENTS/ CHANGES	18
DOOR GLASS ADJUSTMENTS	8	PHASE II — WEATHERSTRIP CHANGES	18
Tilt Adjustment	8		
Up-Stop Adjustment	9		
Forward-Rearward Adjustment	9		
HATCH INFORMATION	9		
Hatch Adjustments	9		
Latch Handle Replacement	9		
Hatch Storage	9		
Hatch Maintenance	11		

INTRODUCTION

The 1981-1982 Ford Mustang and Mercury Capri models have a T-Roof option, which will include a number of variations in design. This manual will assist with service procedures describing adjustment and repair procedures for 1981 and 1982.

The system involves the door glass mechanism, and door glass seals, as well as the T-Roof hatch and roof frame assembly. A change in the door glass system was necessary because the window frame that normally supports the glass is removed. To make up for the variations in glass to seal contact, a number of adjustments were built into the T-Roof system so that sealing and flushness to roof hatches can be maintained.

This manual has been set up for what will be referred to as two “phases” of the T-Roof production.

Phase I is the original 1981 and early 1982 model design. It utilizes the original “sail” type side view mirror, with the T-Roof door components encompassing the mirror.

Phase II is the second design of the T-Roof and is used in later 1982 model production. This design eliminates the original “sail” type side view mirror and utilizes a free standing side view mirror. Many of the other parts in this Phase II system are interchangeable with the Phase I, however some are not.

Examining mirror location can immediately determine which system is on your vehicle. This must be determined for correct ordering of service parts. The final section of this manual covers many part specification changes for Phase II application.

The objective of this book is to help the technician accomplish the following:

- Determine whether a vehicle has the Phase I or Phase II system.
- Determine whether an improperly sealed system is due to a component problem or if the system requires adjustment.
- Determine the adjustment procedure required to correct the problem, and check the adjustment properly after the correction is made.
- Detect damage caused by abuse, neglect, or improper storage of hatches or poor maintenance of the system.
- Identify component level used on the unit and component replaceability with the Phase II components.

In short, understanding the system and the proper adjustments or replacements will result in better sealing, and reduces repeat repairs. With this in mind we can go into the details of both servicing and maintaining the T-Roof system.

DESCRIPTION OF T-ROOF SYSTEM

DESCRIPTION OF T-ROOF SYSTEM

Weatherstrips

The system utilizes two different weatherstrip pieces. One lines the roof opening and extends down the door pillars and the other is on the edge of the T-Roof hatch itself. (Fig. 1)

Roof Panel Assembly (Hatch) with Latches

Two locking pins secure the hatch to striker plates on the car body. (Fig. 2)

Door Glass Up-Stops

Since the window frame was removed, one important added window adjustment on the door glass mechanism is the window "up-stop". Shown here are the adjustment screws and brackets for the proper adjustment of the window. (Fig. 3)

Window Adjustments

Aside from the door glass up-stop adjustments, three other adjustment variations can be made to achieve proper window positioning for a good seal. These are: a) window tilt adjustment (in-out adjustment) b) fore-aft adjustment, (adjustment fore-aft horizontal tilt) c) forward-rearward adjustment (entire glass can move back-forth) (Fig. 4)

Drain System

When the weatherstrips and other components are properly adjusted, drainage flow should follow the paths as shown. (Fig. 5) Water should NEVER drain down the INSIDE of the door pillars, if weatherstrip is in good condition and is adjusted properly.

NOTE: Window must be closed to prevent water draining down weatherstrips from entering car.

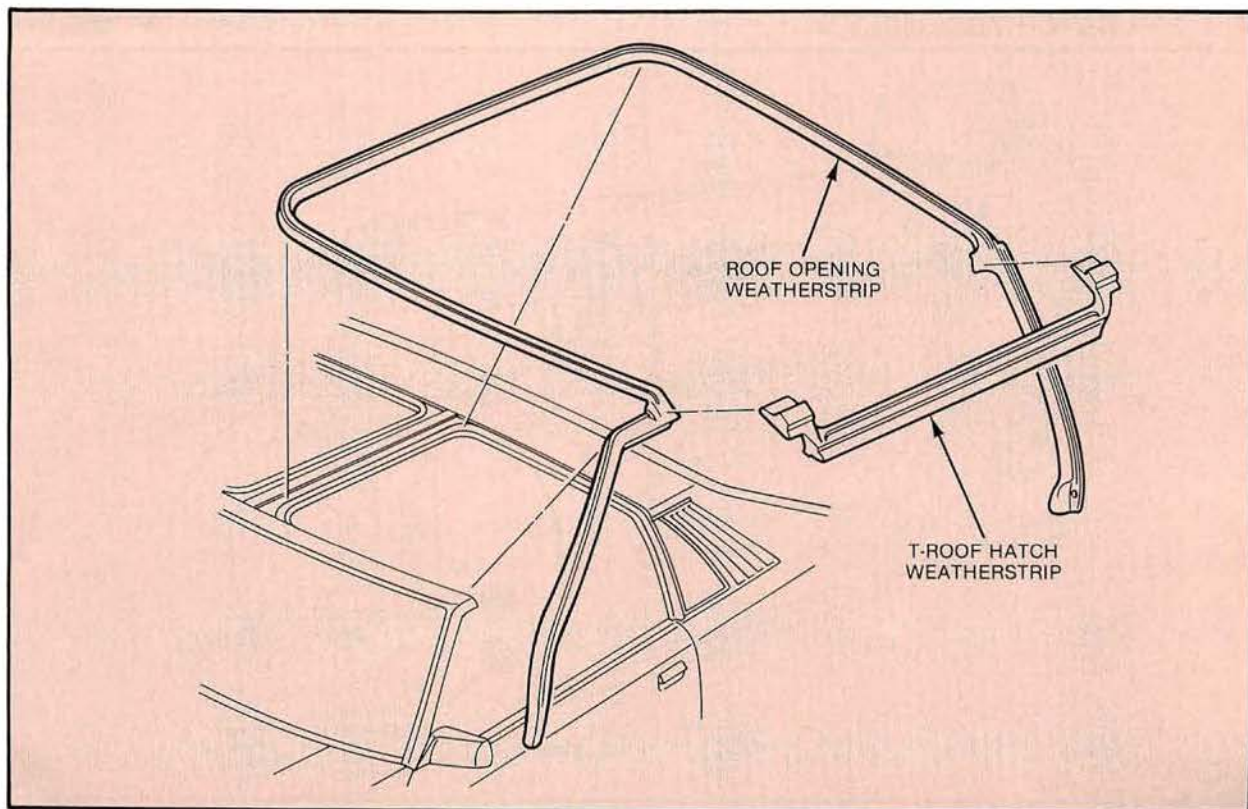

FIG. 1 — WEATHERSTRIPS

DESCRIPTION OF T-ROOF SYSTEM

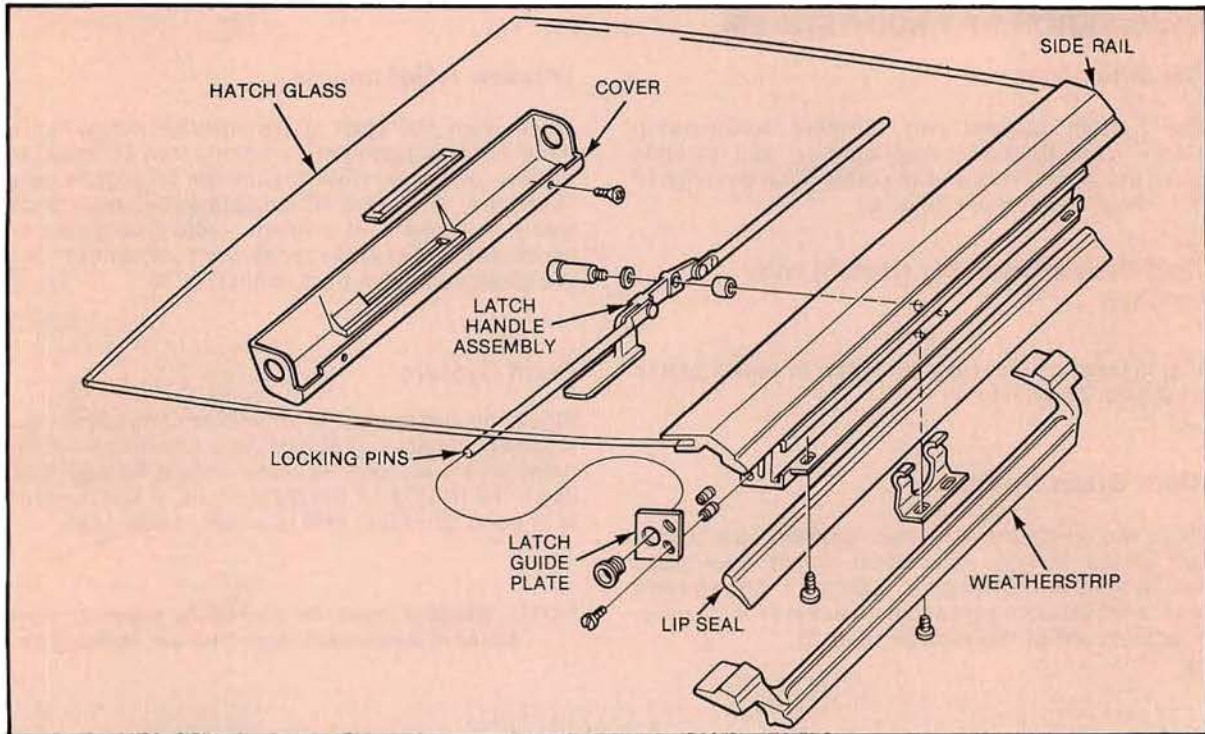

FIG. 2 — HATCH ASSEMBLY

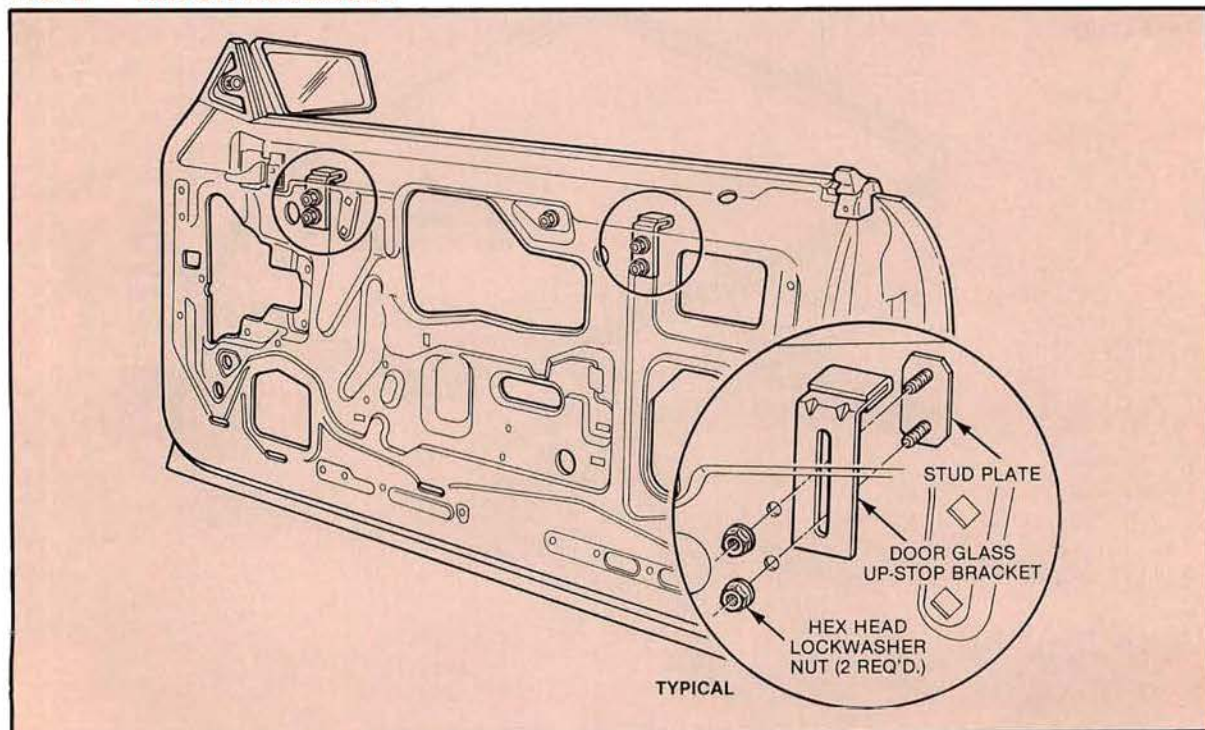

FIG. 3 — DOOR GLASS UP-STOP

DESCRIPTION OF T-ROOF SYSTEM

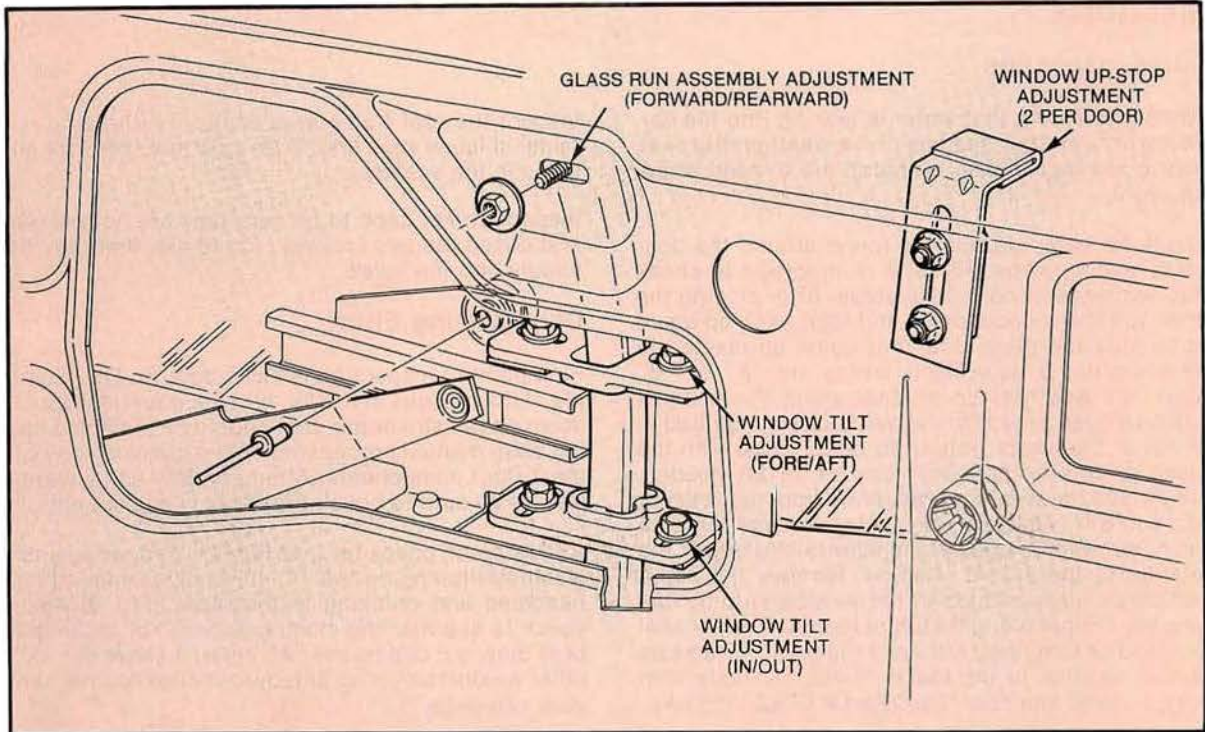

FIG. 4 — DOOR WINDOW ADJUSTMENTS

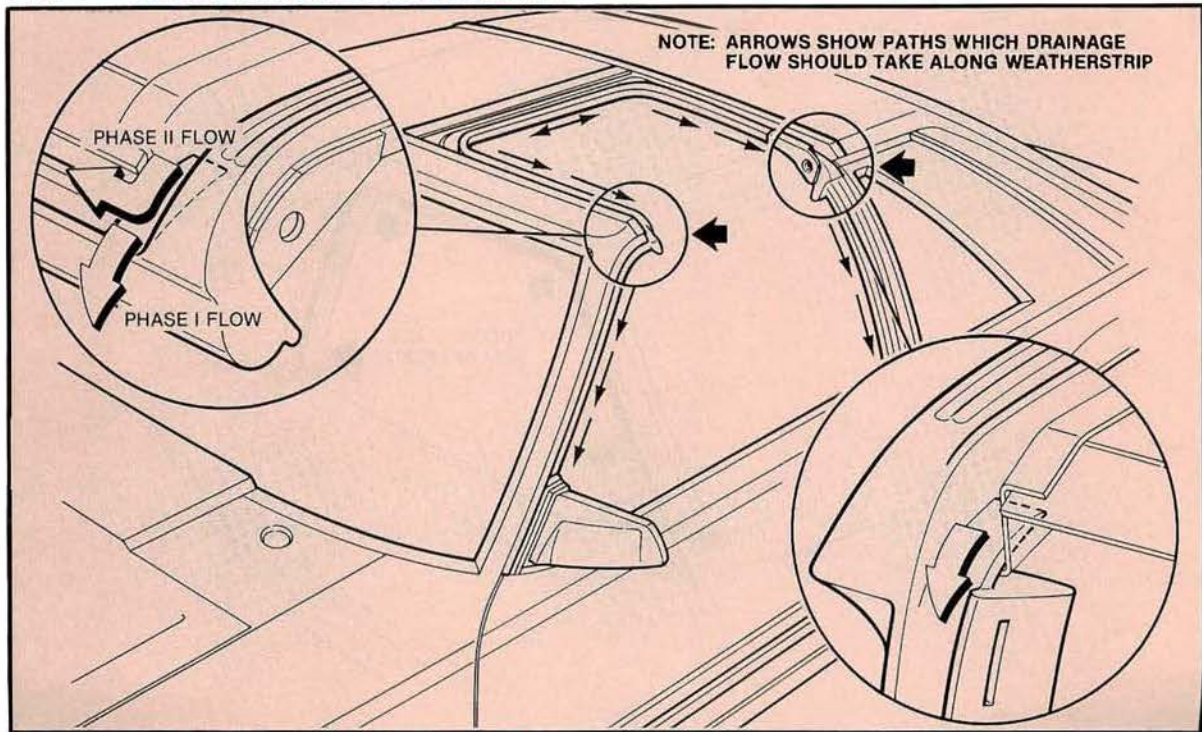

FIG. 5 — WEATHERSTRIP WATER FLOW

DIAGNOSIS

DIAGNOSIS

Initial Inspection

When it is known that water is leaking into the car, do not immediately assume that a weatherstrip seal, door glass mechanism, or hatch are in need of adjustment.

Check for gaps. If gaps are found around the door glass sealing plane (Fig. 6) it is important to check this sequence of corrective steps. After closing the door, roll the window down and then back up again to be sure the glass does not come up inside the weatherstrip. If gaps occur along the "A" or "B" pillar, the weatherstrip retainer along those areas can be moved inward or outward, as well as tilted in or out at the top or bottom to better align with the glass. If this adjustment appears to be needed, simply pull the weatherstrip gently from the retainer and you will see the screws going through the slotted holes. (Fig. 7) Loosen the screws and adjust the retainer to the proper position. Remove the hatch and check the condition of the weatherstrip by running your finger along its entire length. If either seal is ripped or torn, they will need replacing. The seals should be slick to the touch. If not, lubricate with pure silicone lubricant (Ford Part # D7AZ-19553-A).

Inspect the roof frame area of the weatherstrip retainer silicone seal. (Fig. 7) Be sure that there are no holes in the sealant.

Inspect striker caps to be sure they are not broken and check the two locking pins to see that they fit snugly into the holes.

Door Closing Effort

First point of inspection is basic door fit. For example, if door closes in too far, or if the door rides up or down on the striker bar, that should be remedied using shop manual procedures before checking any of the T-Roof components. After any door adjustment, always be sure to check the window adjustments.

At this point, check for interference of door against weatherstripping on the "A" pillar by examining for bunching and crimping in that area (Fig. 8). Also, check to see that the closing door is not striking a bent blow-out clip on the "A" pillar. If either the "A" pillar weatherstripping or blow-out clips require service, see page 11.

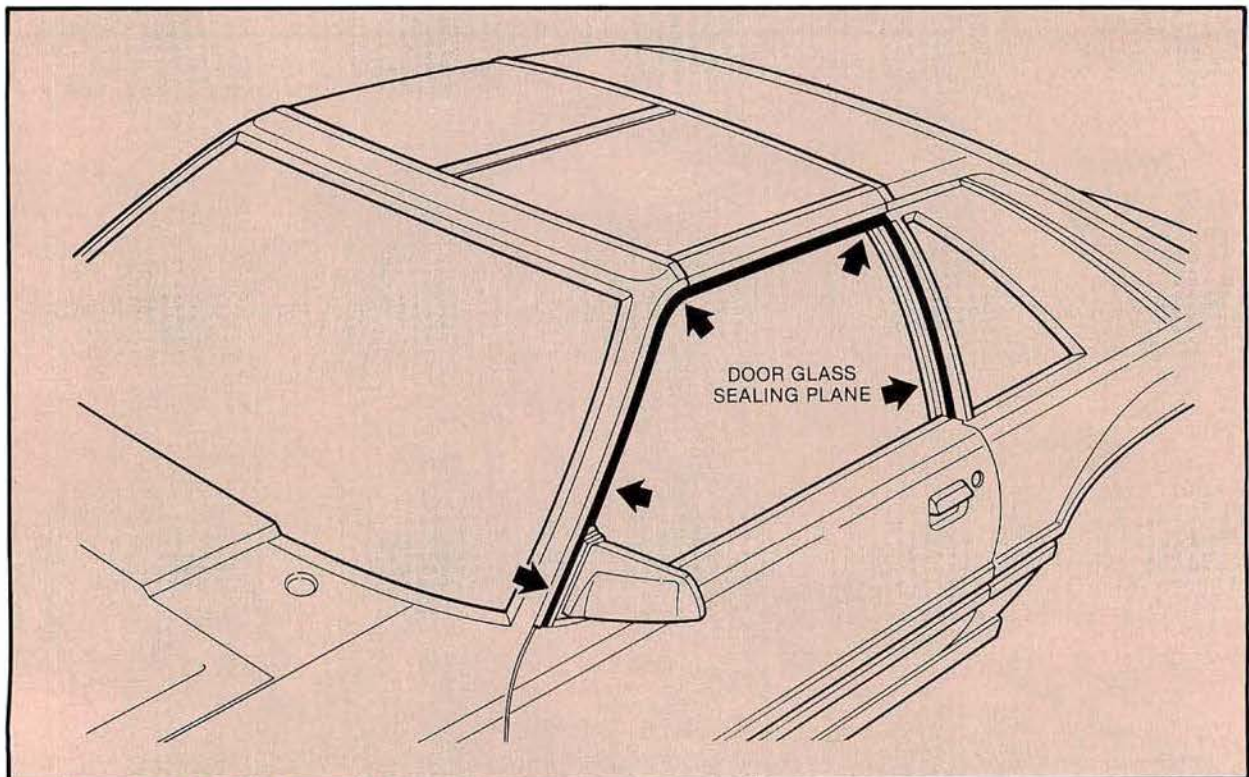

FIG. 6 — DOOR GLASS SEALING PLANE



WE SUPPORT VOLUNTARY MECHANIC CERTIFICATION